



User Manual

“Touch” control button

“Touch” control button

User manual for Sky-Frame systems with an SI-1000 electric drive and “Touch” wireless control panel.



Sky-Frame AG

Langfeldstrasse 111
CH-8500 Frauenfeld
Switzerland

Phone: +41 52 724 94 94
E-mail: info@sky-frame.com
Internet: www.sky-frame.com

Sky-Frame Inc.

5912 Blackwelder St
Culver City, CA 90232
USA

Telephone: +1 (424) 298-8906
E-Mail: info@sky-frame.com
Website: www.sky-frame.com

User Manual

“Touch” control button Table of contents

Table of contents	1	General information and symbols	14.4.1.1
	2	Introduction	14.4.2.1
	2.1	Control button functions	14.4.2.1
	3	Safety	14.4.3.1
	3.1	Safety measures	14.4.3.2
	3.2	Operating the control button	14.4.3.4
	3.3	Notes concerning use of control button	14.4.3.5
	4	Part designations	14.4.4.1
	5	User function	14.4.5.1
	5.1	Opening and closing the door	14.4.5.1
	5.1.1	Opening	14.4.5.1
	5.1.2	Closing	14.4.5.1
	5.2	Button block	14.4.5.2
	5.2.1	Activating the button block	14.4.5.2
	5.2.2	Deactivating the button block	14.4.5.2
	5.2.3	Active button block indication	14.4.5.2
	6	Operating panel	14.4.6.1
	6.1	Removing the operating panel	14.4.6.1
	6.2	Fitting the operating panel	14.4.6.1
	7	Battery	14.4.7.1
	7.1	Battery status	14.4.7.1
	7.2	Replacing the battery	14.4.7.1
	8	Configuration	14.4.8.1
	8.1	Coupling devices	14.4.8.1
	8.1.1	Performing pairing	14.4.8.1
	8.1.2	Delete pairing – receiver	14.4.8.2
	8.1.3	Delete pairing – transmitter	14.4.8.2
	8.2	Direction reversal	14.4.8.4
	9	Technical data	14.4.9.1
	9.1	Control button	14.4.9.1
	9.2	Receiver	14.4.9.2
	10	Troubleshooting	14.4.10.1
	11	Countries and regions	14.4.11.1

User Manual

“Touch” control button General information

1. General information 1.1 Information concerning this manual

This manual explains how to use a Sky-Frame system which is operated using the “Touch” control button in a safe and efficient way. The manual is a constituent of the system and must be retained.

The manual must always be read carefully before starting work. A basic prerequisite for safe operation is adherence to all of the specified safety instructions and action instructions in this manual.

The illustrations in this manual are intended to provide a basic understanding and may differ from the actual design.

1.2 Explanation of symbols

Safety instructions:

The safety instructions in this manual are marked with symbols. The safety instructions are preceded by signal words that indicate the level of danger. Adhering to the safety instructions will help to avoid accidents, injuries and damage to property.

▲ WARNING



WARNING! (Danger to life and limb)

This symbol indicates a potentially dangerous situation that could lead to death or serious injury if it is not avoided.

▲ CAUTION



CAUTION! (Risk of error)

This symbol indicates a potential risk of fault that could cause damage to property if it is not heeded.



NOTE:

This symbol highlights useful tips and recommendations for efficient and fault-free operation.

User Manual

“Touch” control button General information

Special safety instructions

In order to point out particularly dangerous situations, the following symbols are used in safety instructions:

⚠ DANGER



DANGER! (Electric shock)

This combination of symbol and signal word marks dangers caused by electrical current.

Failure to observe the safety instructions will result in a risk of serious or fatal injury.

Symbols in this manual

The following symbols and highlighting are used in this manual to mark action instructions, result descriptions, lists, references and other elements.

1. Marks step-by-step action instructions

→ Marks a status or an automatic sequence resulting from an action step.

- Marks lists and list entries with no fixed order.

[→ Page No.] References to the pages of this manual.

Risk assessment

Since the system is moved using the Sky-Frame Touch control button in low-energy mode (in accordance with DIN EN 16005) with self-holding, a **risk assessment** must be carried out [→ page 11.3.4.1] and signed **before activating** this function at the drive.



In accordance with DIN 18650, which describes technical safety requirements for automatic door and sliding window systems in accordance with directive 2006/42/EC (machinery directive), prior to installing the automatic sliding window system a **detailed risk assessment must be carried out** in order to ensure that the automatic sliding panels can be operated safely.

User Manual

“Touch” control button General information

Liability restriction

All information and notes in this manual have been put together taking the applicable standards and regulations, the state of technology, our knowledge and our many years of experience into consideration.

The manufacturer does not accept liability for damage caused by:

- Failing to follow the instructions in the manual
- Failing to use the equipment for its intended purpose
- Making technical modifications
- Using non-approved spare parts

The actual scope of delivery may differ from the information in this manual in the event of customised versions, the use of additional ordering options or because of technical changes.

The obligations agreed in the delivery agreement, the manufacturer's general business terms and conditions and delivery conditions, and the legal regulations that were applicable when the agreement was signed are applicable.

Warranty conditions

The warranty conditions are included in the manufacturer's general business terms and conditions.

Customer service

Please contact your responsible Sky-Frame partner if you have any questions or concerns.

User Manual

“Touch” control button Introduction

2. Introduction

The wireless Sky-Frame “Touch” control button is equipped with Bluetooth® Low Energy technology (referred to in the following as “Bluetooth”) for Sky-Frame systems with the SI-1000 drive. Coupling the “Touch” control button with the Bluetooth-compatible Sky-Frame receiver unit at the drive allows the following functions to be carried out wirelessly (with an operating range of approx. 10 m in any direction).

2.1 Control button functions

Functions of the “Touch” control button:

- Start element movement in the opening direction
- Stop element movement during travel
- Start element movement in the closing direction
- Activate / deactivate the button block

In order to avoid accidents, it is essential to first read the “Safety” chapter before use [→ page 14.4.3.1].

These operating instructions must be read in full in order to use the product correctly.

⚠ WARNING



WARNING!

Danger from incorrect use!

During manual operation of the system, buttons can be inadvertently pressed which can open or close the system.

If you would like to avoid inadvertent activation, you should activate the button block at the “Touch” control button [→ page 14.4.5.2] or remove the battery. The operating range of the control button can vary depending on the usage conditions. More information can be found under “Notes on using the control button” [→ page 14.4.3.5].

Please note that Sky-Frame does not accept any liability for loss or damage to the product resulting from use of erroneous settings with the wireless communication function. Nor does Sky-Frame accept any liability for other losses or damage caused by the use of the product.

User Manual

“Touch” control button Safety

3. Safety

This section provides an overview of all important safety aspects for providing the user with the best possible protection and for ensuring that operation is safe and problem-free. Failure to observe the action instructions and safety instructions in this manual can lead to considerable danger.

Use for intended purpose

The “Touch” control button is exclusively for use with the SI-1000 drive, and has been designed and constructed for the intended purpose of use described in this manual.

Intended purpose of use also includes complying with all of the specifications in this manual. Any other use is considered to be incorrect. Claims of any kind for damage caused by incorrect use will not be entertained.

Basic dangers

In order to minimise health hazards and avoid dangerous situations, the safety instructions listed here and in the other chapters of this manual must be followed.

Electric current

⚠ DANGER



DANGER!

Risk of fatality due to electric current!

Coming into contact with live components will result in a direct risk of fatality due to electrocution.

Damage to the insulation or individual components can be life-threatening.

- **Have all work on the electrical system carried out by trained experts.**
- In the event of damage to the insulation, switch off immediately and have it repaired.
- Keep moisture away from live components. This can lead to short circuits.
- Never undo screws on the system and remove the service cover.

User Manual

“Touch” control button Safety

3.1 Safety measures



The following safety precautions are intended to prevent you or anyone else from becoming injured or damaged. Please ensure that you have read and understood these safety measures exactly before using the control button.

If you notice any malfunctions, problems or damage on the device, please contact Sky-Frame customer service or the specialist company from which you purchased the product.

Please note the following safety precautions in order to prevent fires, the development of intense heat, escaping chemicals, explosions and electric shocks:

- Only use the batteries, power sources and accessories which are specified in these operating instructions. Do not use batteries which you have made yourself or modified, or use the control button itself if it is damaged.
- Do not short-circuit the battery, take it apart or make any modifications to it. Do not bring the battery into contact with heat or soldering material. The battery must not come into contact with fire or water. Do not subject the battery to strong physical impacts.
- Do not insert the battery with the plus and minus terminals reversed. Before disposing of the battery, insulate the electrical contacts with a strip of adhesive tape. Direct contact with other metallic objects or batteries could lead to a fire or an explosion.
- Remove the battery immediately if liquid escapes, the shape or colour of the battery changes or if smoke development occurs. Proceed with caution in this case in order to avoid burns. If you continue to use the battery there is a risk of fire, burns or electric shocks.

User Manual

“Touch” control button Safety

Safety measures



- Keep batteries, the battery compartment cover etc. out of the reach of children and babies. Consult a doctor immediately if a child or baby swallows the battery, the battery compartment cover etc. The chemicals in the battery can damage the gastrointestinal tract.
- Electromagnetic waves radiated by the product may interfere with instruments or medical devices.
- If the product is going to be used by a child, a detailed explanation of how to use it must be provided by an adult beforehand. Always supervise children when they are using the product. Improper use can lead to electric shock or injuries.
- Do not allow the product to become wet. If the product falls into water or it is penetrated by water or metal, remove the battery immediately. This will avoid fires, electric shocks and burns.
- Do not use substances containing thinner, benzene or other organic solvents to clean the product. Risk of fire or health risk.

Measures for avoiding damage

Do not immerse the control button in water. Wipe off droplets of water with a dry, clean cloth.

If the product has been exposed to salty sea air, wipe it with a clean, damp and well wrung-out cloth.

User Manual

“Touch” control button Safety

3.2 Operating the control button

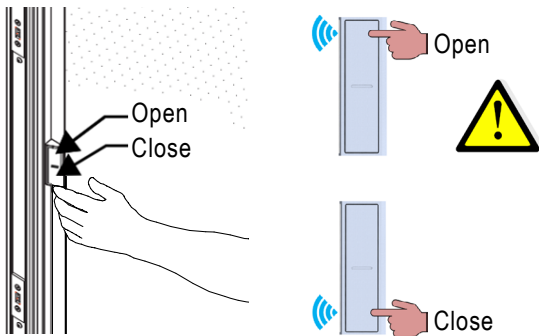

Operate the control button as shown in the illustration during operation.

WARNING!

Never reach into the closing or opening area while the system is in motion!

WARNING

The marked locations in the illustration below show the possible danger areas on the system, where persons are at risk of injury in the event of improper behaviour.

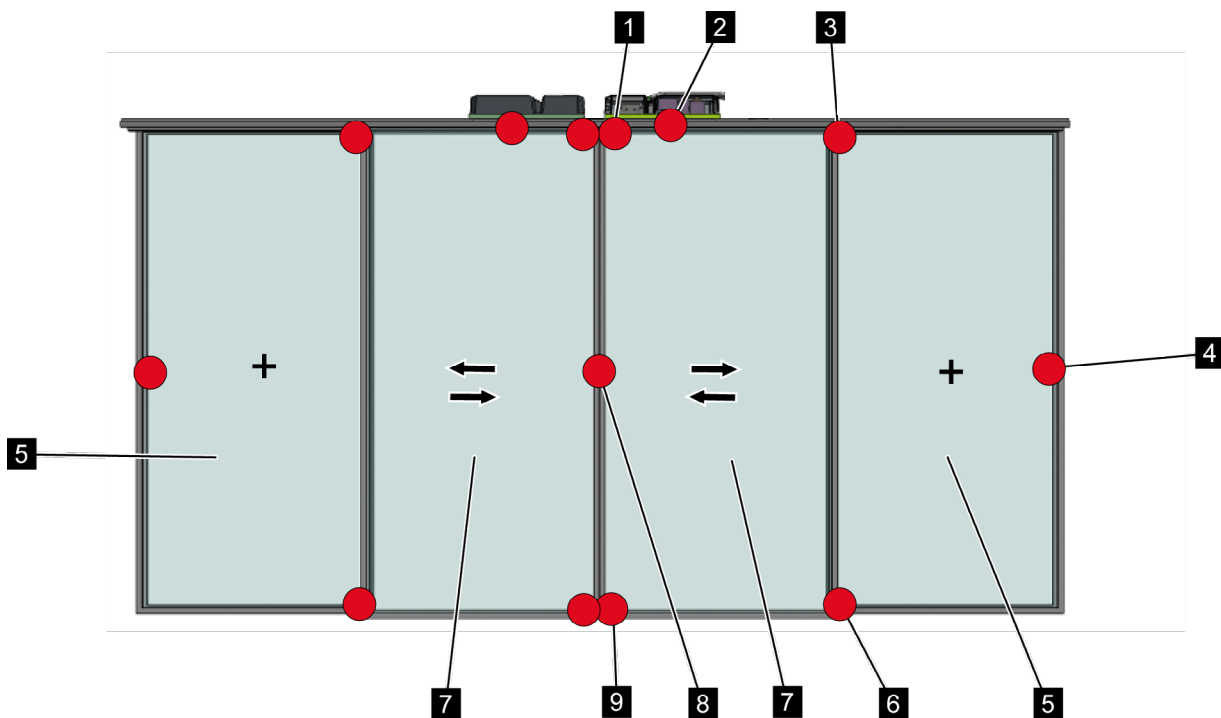

WARNING



Danger for the body:
(Crushing)

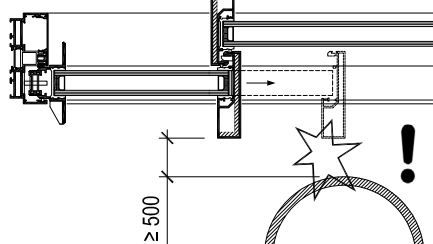

Danger areas:



- 1 Between top edge of leaf and runner when closing
- 2 At the drive belt when closing and opening
- 3 Between top edge of leaf and runner when opening
- 4 Between window leaves and between window leaf and frame when opening
- 5 Fixed element
- 6 Between bottom edge of leaf and runner when opening
- 7 Active leaf
- 8 Between window leaves and between window leaf and frame when closing
- 9 Between bottom edge of leaf and runner when closing

User Manual

“Touch” control button Safety

3.3 Notes concerning use of control button

If the operation of the control button is delayed or affected or if any other problems occur, please attempt to carry out the following troubleshooting measures:

Distance between control button and receiver

The maximum operating range between the transmitter and the receiver is approximately 10 m in all directions. It may not be possible to carry out the remote control functions further away from the receiver.

Transmission affected by objects blocking the signal

The operating range of the control button may be reduced if persons or objects are present between the control button and the receiver at the drive. The operating range of the device may be reduced if the device is covered. In cases such as this, remove obstacles which could affect the wireless transmission or reduce the distance from the receiver in order to be able to carry out the required remote control functions.

Radio wave interference in the 2.4 GHz band

This product establishes communication via radio waves in the 2.4 GHz frequency band. For this reason, the operation of the control button may be delayed or affected if there are electronic devices using the same frequency in the vicinity.

- The electronic devices which use the same frequency band include WLAN devices, smartphones, Bluetooth devices, microwave devices, cordless telephones and other similar devices.
- If radio wave interference occurs between the transmitter and the receiver and a nearby electronic device, either stop using the electronic device, or use it further away.

User Manual

“Touch” control button Part designations

4. Part designations

All parts are described in the following.

4.1 Sky-Frame Touch transmitter

The “Touch” control button acts as a Bluetooth transmitter.

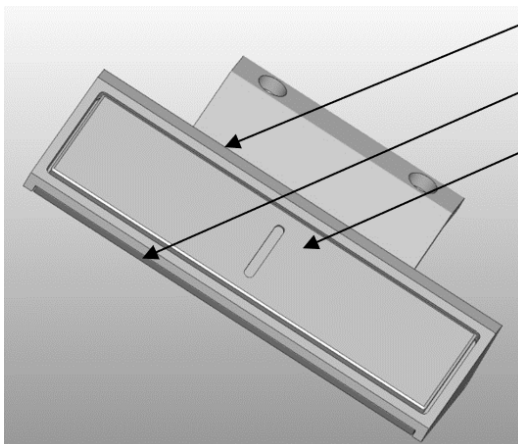

- Handle housing
- Fibre optic cable
- Operating panel / battery compartment cover



The control button is supplied without a battery
Type: CR1632 (3 V)

Entire control button

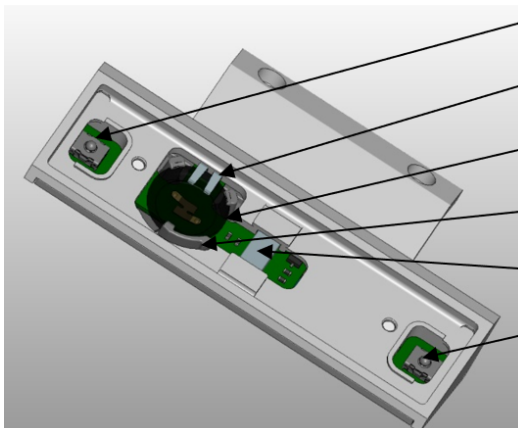

- Control button S2
- Battery holder
- Button cell battery
- Battery locking mechanism
- Magnet storage
- Control button S1

Control button without operating panel

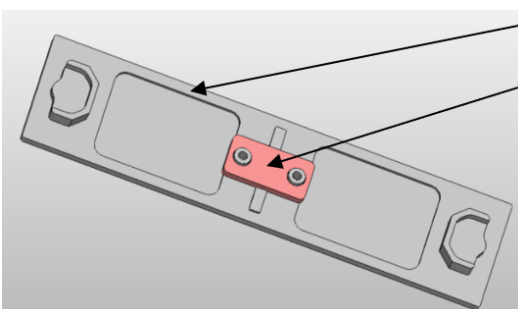

- Operating panel / battery compartment cover (rear)
- Magnet surface

Rear of operating panel

User Manual

“Touch” control button Part designations

4.2 Sky-Frame Touch receiver

The additional module with the master drive (A) acts as a Bluetooth receiver.

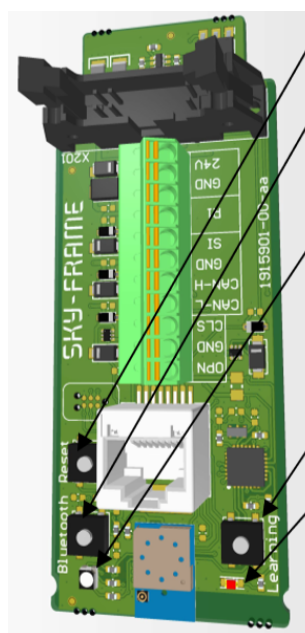

Bluetooth reset button

Bluetooth button

Bluetooth status LED

Drive SI-1000 teach-in button

Drive SI-1000 status LED

Additional module

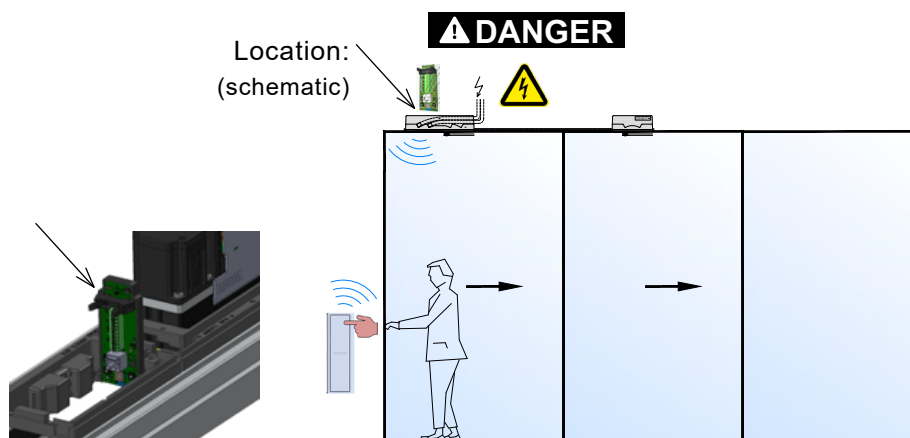

Location:
(schematic)

⚠ DANGER

User Manual

“Touch” control button User functions

5. User functions

All functions of the “Touch” control button are described in the following.

5.1 Opening and closing the door

5.1.1 Opening

To open the system, briefly press the **top** button of the control button.

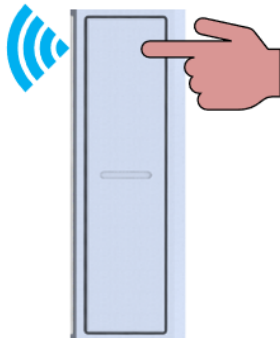

→ The top LED briefly illuminates in cyan, and the system opens.

For technicians:

The Bluetooth status LED on the Sky-Frame “Touch” receiver briefly illuminates in green when the OPEN signal is received.

5.1.2 Closing

To close the system, briefly press the **bottom** button of the control button.

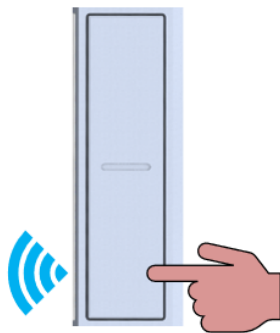

→ The bottom LED briefly illuminates in cyan, and the system closes.

The Bluetooth status LED on the Sky-Frame “Touch” receiver briefly illuminates in blue when the CLOSE signal is received.

Stopping the movement

To stop the system during movement, briefly press any button on the control button.



→ The respective LED briefly illuminates in cyan, and the system stops.

The Bluetooth status LED on the Sky-Frame “Touch” receiver briefly illuminates in green or blue, depending on which button has been pressed to stop the system.

User Manual

“Touch” control button User functions

5.2 Button block

The “Button block” function prevents unintentional movement of the sliding panels.

5.2.1 Activating the button block

To activate the button block, press and hold down one of the two control buttons **for 5 seconds**.

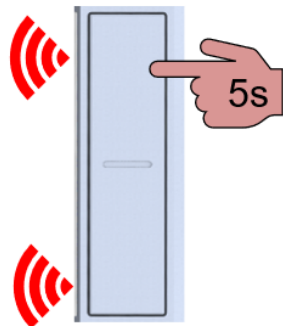

→ The respective LED illuminates in cyan for 5 seconds, then both LEDs flash in red.

The button block is now active, and you can release the control button again.

5.2.2 Deactivating the button block

To deactivate the button block, press one of the two control buttons **for 5 seconds**.

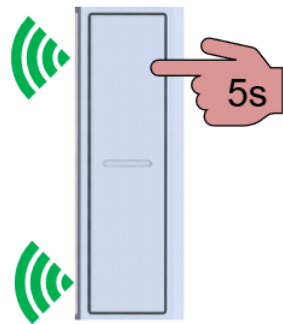

→ The LEDs flash in red for 5 seconds, then both LEDs illuminate in green.

The button block is deactivated and you can release the control button.

5.2.3 Active button block indication

If a button is pressed for less than 5 seconds with the button block activated, both LEDs flash in red for as long as the button is pressed

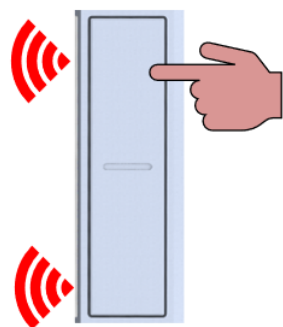

User Manual

“Touch” control button Operating panel

6. Operating panel

The operating panel must be removed to change batteries, delete the coupling of the “Touch” control button or to reverse the direction.

6.1 Removing the operating panel

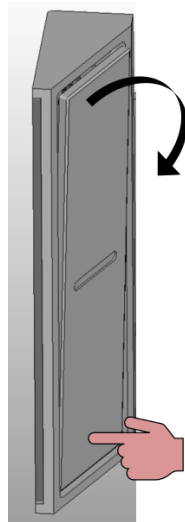

If the “Touch” control button is already connected, first **activate the button block** [→ page 14.4.5.2] to prevent undesirable opening or closing of the system.

Press the bottom of the operating panel and slide a plastic card beneath the upper part of the operating panel.

This separates the magnetic connection between the operating panel and the handle housing, and the operating panel can be removed.

6.2 Fitting the operating panel

To replace the operating panel simply place it onto the basic housing of the “Touch” control button.

→ The operating panel is attracted by the magnets.

Now the button block can be deactivated again [→ page 14.4.5.2].

Check that the button is operating correctly after replacing the operating panel.

⚠ CAUTION



CAUTION!

Danger from incorrect use!

Never press the rocker switch at both sides using force! This can destroy the operating panel.

User Manual

“Touch” control button Battery

7. Battery

Battery status:

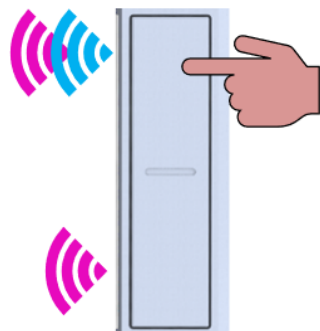

When the battery reaches a critical voltage, this will be indicated by **flashing of the LEDs** when the control button is pressed.

The relevant LED first illuminates in cyan, then both LEDs will begin to flash in pink.

The control button will only continue to operate for a short time after this. The battery must be replaced as soon as possible.

Replacing the battery:

1. To replace the battery, first remove the operating panel [→ page 14.4.6.1].
2. Pull back the locking tab and remove the battery from the battery compartment towards the front and upwards.
3. Slide a new **CR1632 (3 V)** battery into the battery compartment with the + pole end at the top, and secure it beneath the locking tab with a gentle push.

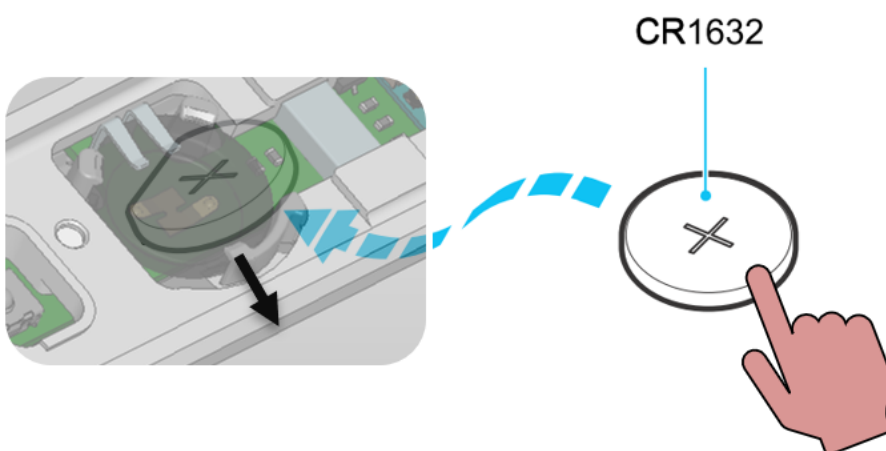

User Manual

“Touch” control button Configuration

8. Configuration

All of the configuration options of the “Touch” control button are described in the following.

This work must only be carried out by trained specialist personnel!

8.1 Coupling devices

To connect the “Touch” control button with the receiver module of SI-1000 drive, proceed as described in the following.

8.1.1 Performing pairing

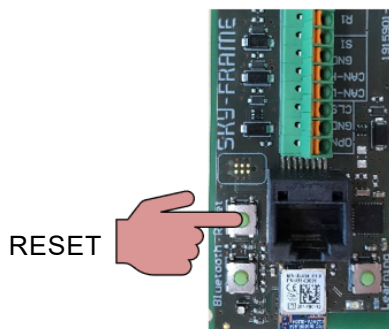

1. First, ensure that the **pairing has been deleted** between the transmitter and the receiver (see “Delete pairing” [→ page 14.4.8.2]).
2. Activate pairing mode at the **receiver** by briefly pressing the Reset button. The Bluetooth status LED flashes constantly in the colour sequence red-green-blue.
3. Now one of the two **buttons** on the transmitter (“Touch” handle) must **be pressed** to activate pairing mode.

The battery must be inserted to do this.

→ Pairing mode is indicated on the handle by both LEDs flashing in blue.

→ The two devices now automatically perform the pairing and exchange the data that is required for a secure connection. During this time, both LEDs on the control button flash in cyan and blue.

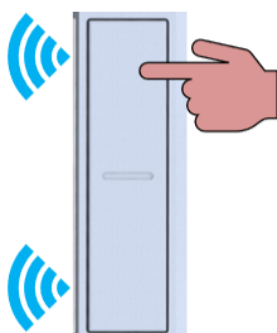

When all LEDs have gone off, the pairing has been successfully completed and the control button can be used.

4. When the TOP operating panel is pressed, the system must move in the **OPEN** direction.

If this is not the case, see “Direction Reversal” [→ page 14.4.8.4].

User Manual

“Touch” control button Configuration

8.1.2 Delete pairing – receiver

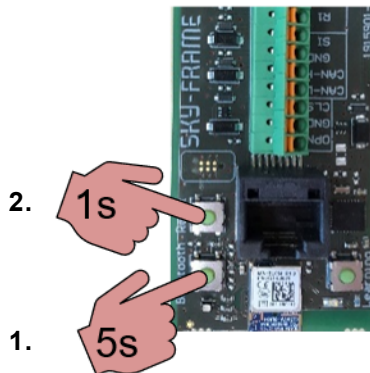

To delete the pairing from the receiver:

1. Press and hold down the **Bluetooth button** for at least **5 seconds**.

→ During this time, the LED flashes rapidly in green.

After 5 seconds, the LED briefly illuminates in red and the button can be released.

2. Then, briefly press the **Reset button** (1 second).

→ The LED switches to a continuous colour sequence of red-green-blue.

The receiver has now been deleted and is ready to be connected to a new “Touch” control button.

8.1.3 Delete pairing – transmitter (Touch control button)

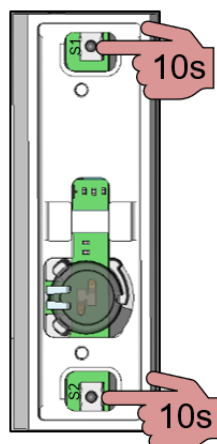

To delete the pairing at the control button:

1. First lift the magnetic operating panel [→ page 14.4.6.1].
2. Then, press and hold down the “S1” and “S2” buttons beneath it **SIMULTANEOUSLY** for at least **10 seconds**.

→ Both LEDs flash in green for the first 5 seconds, then flash in red for 5 seconds.

→ After 10 seconds, both LEDs illuminate continuously in red.

The buttons can now be released.

The pairing is now deleted and both LEDs flash in blue.

The transmitter can now be connected to a receiver again. The pairing remains active for 10 seconds and then switches to sleep mode, and the LEDs go off.

To reactivate, press any button.

User Manual

“Touch” control button Configuration

General notes about pairing:



- It is advisable to teach in the drives of the system and carry out a complete reference run before the devices are coupled for the first time. [→ Installation instructions “SI-1000 drive” 13.4., Chapter 9]
- It is not possible to simultaneously couple two or more control buttons with a receiver unit.
- If you wish to couple a control button with a receiver unit that is already coupled with another control button, the control button and the receiver must be deleted before making the new connection. Delete the registration of the connections and couple the required devices.
- In order to carry out coupling, ensure that a CR1632 (3 V) button battery has been placed into the control button and the drive has a power supply. Otherwise, it will not be possible to couple the devices.
- The coupling remains stored until it is actively deleted, and is retained if the power supply at the control button or the drive is interrupted. The remote control functions can continue to be used when the power supply is restored.

User Manual

“Touch” control button Configuration

8.2 Direction reversal

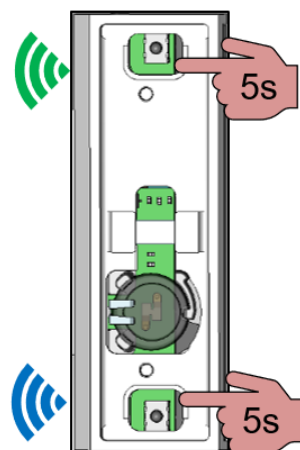

To reverse the direction (OPEN / CLOSED) of the control buttons (TOP / BOTTOM), proceed as follows:

1. First lift the magnetic operating panel [→ page 14.4.6.1].
2. Then, press and hold down the “S1” and “S2” buttons beneath it **SIMULTANEOUSLY** for at least **5 seconds** (but less than 10 seconds).

→ Both LEDs flash in green.

→ After 5 seconds, both LEDs begin to flash rapidly in red.

3. Now, both buttons can be released.

→ The LEDs now illuminate for 5 seconds in the following colours, indicating the new setting:

Green = OPEN
Blue = CLOSE

The procedure can be repeated as often as required.



Only hold down the two buttons for 5 seconds!
After 10 seconds, the pairing between the transmitter and the receiver is deleted and must be performed again.

User Manual

“Touch” control button Control button technical data

9.1 Control button technical data

Technical data for “Touch” control button.

Type: SF Touch Transmitter (Art. No. 402508)

Compliance standards: Bluetooth specification version 5
(Bluetooth Low Energy technology)

Operating range: approx. 10 m* from the control button, in any direction
* Provided that there are no obstacles between the control button and receiver and there is no radio interference.

Power supply: CR1632 Lithium button cell battery (3 V)

Battery life: approx. 2 years (depending on usage)

Dimensions (L x W x H): approx. 90 x 49 x 23 mm

Weight: approx. 43 g (with battery)

Operating temperature range: 0 °C - 40 °C

Humidity operating range: ≤ 85% (non-condensing)

Control light status:

Indicator light	Status
The relevant LED illuminates in CYAN when pressed	Normal operation
Both LEDs flash in RED	Button block active
Both LEDs illuminate in GREEN	Button block deactivated
Both LEDs flash in BLUE	Control button ready for coupling
Both LEDs flicker in CYAN and BLUE	Coupling in progress
The relevant LED illuminates in CYAN when pressed, then both LEDs flash in PINK	Low battery level → Replace battery as soon as possible

For technicians only:

Update mode	Status
LED continuously illuminated in GREEN	DFU mode active
LED continuously illuminated in BLUE	Coupled in DFU mode
LED flickers in CYAN	Update is being transmitted

(DFU = Device Firmware Upgrade)

Subject to changes to the product data and appearance without advance notice.

User Manual

“Touch” control button Receiver technical data

9.2 Receiver technical data

“Touch” receiver technical data.

Type: SF Touch Receiver (Art. No. 402507)

Compliance standards: Bluetooth specification version 5
(Bluetooth Low Energy technology)

Operating range: approx. 10 m* from the control button, in any direction
* Provided that there are no obstacles between the control button and receiver and there is no radio interference.

Power supply: U = 24 VDC, I = <50 mA of SI-1000 drive unit

Dimensions (L x W x H): approx. 101 x 40 x 30 mm

Weight: approx. 28 g

Operating temperature range: 0 °C - 40 °C

Humidity operating range: ≤ 85% (non-condensing)

Control light status:

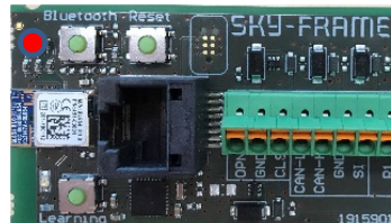

For technicians only:

Update mode	Status
LED continuously illuminated in GREEN	DFU mode active
LED continuously illuminated in BLUE	Coupled in DFU mode
LED flickers in CYAN	Update is being transmitted

(DFU = Device Firmware Upgrade)

Indicator light	Status
LED flashes in RED+GREEN+BLUE	Receiver ready for coupling
LED flashes continuously in GREEN	Bluetooth button is pressed
LED flashes 1x briefly in GREEN	OPEN pressed at control button
LED flashes 1x briefly in BLUE	CLOSE is pressed at control button

Subject to changes to the product data and appearance without advance notice.

User Manual

“Touch” control button Troubleshooting

10. Troubleshooting

If the device does not function as described, check:

1. Does the drive have a power supply?
2. Is there a battery in the control button?

If there is still no connection to the device, contact your responsible Sky-Frame partner.



A check must be carried out annually by a specialist.

User Manual

“Touch” control button Countries and regions

11. Countries and regions



Countries and regions in which the use of wireless communication functions is permitted.

The use of wireless communication functions may be restricted or forbidden in certain countries.

The infringement of national or local regulations may be punishable by law.

Sky-Frame accepts no liability for problems originating from the use of wireless communication functions in other countries and regions.

Bluetooth frequency range: 2402 MHz - 2480 MHz
Maximum Bluetooth output: 7.14 dBm

Hereby, Sky-Frame declares that the radio equipment type of the following models is in compliance with Directive 2014/53/EU:

Art. No. 402508	SF Touch Transmitter
Art. No. 402507	SF Touch Receiver



The full text of the EU declaration of conformity is available at the following internet address:

EN: <https://www.sky-frame.com/en/ec-declarations-conformity/>

Disclaimer

All specifications are non-binding and must not be regarded as a guarantee.

Sky-Frame AG reserves the right to modify, extend or delete the specifications, product data and appearance without notice. The latest version of this document is always decisive, and can be downloaded from www.Sky-Frame.com.

© 2021 Sky-Frame AG