

# WORKING WITH SKY-FRAME.

US



SKY-FRAME















**A VIEW,  
NOT A  
WINDOW.**

Working with Sky-Frame means creating living environments of unparalleled beauty, comfort and elegance. The frameless sliding door is a modular system that combines Swiss engineering ingenuity with timeless style, resulting in architectural elements that exude quality in every regard.



# SKY-FRAME SYSTEM.

The various systems can be combined with glass panels of different thicknesses and thus provide an aesthetically pleasing solution with a range of useful functions. As soon as you have chosen the ideal system, the appropriate glazing can be selected. You can further tailor your system with a wide selection of additional features.

SYSTEM		CLASSIC Straight sliding doors	ARC Curved sliding doors	SLOPE Inclined sliding doors	PIVOT Pivot door
OPTION Track system	 <b>Original</b> Visible transition	●	●	*	
	 <b>Plain</b> Hidden, seamless transition	*			
TECHNOLOGY Glazing	 <b>Sky-Frame 1</b> Single glazing	○			
	 <b>Sky-Frame 2</b> Double-glazed insulating glass	●	○	*	●
	 <b>Sky-Frame 3</b> Triple-glazed insulating glass	●	○	*	●
FEATURES	 <b>Fly</b> Insect screen	●			
	 <b>Drive</b> Electric drive	●	*	*	
	 <b>Guard</b> Increased anti-burglary protection	●	*	*	*
	 <b>Pocket</b> Hidden sliding door	●	○	*	
	 <b>Inline</b> Flush-fitted glass panels	●	*	*	
	 <b>Gun</b> Bulletproof version	○			
	 <b>Hurricane</b>	○			
	 <b>Color</b> Customization	●	●	●	●

● standard   ○ only with the Original option   \* on request

## SYSTEM

### Sky-Frame Classic

The rectilinear Classic door system has timeless appeal. True to the Bauhaus vision, the ceiling-height glass facades help to create a minimalist architecture in which the view takes center stage.

**For technical details, see page 06.**

### Sky-Frame Arc

The organic forms of the Arc model serve to soften the contours of domestic architecture. The curved sliding panels offer a bold counterpoint to the linearity of the spatial and facade composition.

**For technical details, see page 08.**

### Sky-Frame Slope

The Slope system allows the sliding doors to be installed at an angle. The inclined glass units can either extend into the room or project outwards from the facade. The distinctive spatial geometry offers a unique living experience.

**For technical details, see page 10.**

### Sky-Frame Pivot

Thanks to its asymmetrically positioned axis, Sky-Frame Pivot, the glass-paneled pivot door, swings open easily with just a gentle push. The multipoint locking system guarantees safety and security.

**For technical details, see page 12.**

## OPTION

### Sky-Frame Original

A feeling of vast, wide-open space, even when the doors are shut: a track system that is fully concealed in the floor allows the doors to be completely frameless and transparent. Sky-Frame Original guarantees the optimal temperature inside while keeping heat and cold outside.

**For technical details, see page 14.**

### Sky-Frame Plain

What sets Sky-Frame Plain apart is a hidden, seamless transition between the inside and the outside. The sliding door glides along a narrow gap and is fitted flush with the floor. The space between these tracks is covered by the same flooring as the interior of the room, blurring any lines or divisions, creating a free flowing transition.

**For technical details, see page 16.**

## TECHNOLOGY

### Sky-Frame 1

The single-glazed Sky-Frame 1 system (½") is suitable for applications without thermal insulation requirements.

**For technical details, see page 20.**

### Sky-Frame 2

The double-glazed Sky-Frame 2 assemblies (1 ¾") meet strict sound and thermal control requirements.

**For technical details, see page 22.**

### Sky-Frame 3

The triple-glazed Sky-Frame 3 technology (2 ¼") further enhances the thermal insulation performance to meet the most stringent standards.

**For technical details, see page 24.**

## FEATURES

### Sky-Frame Fly

Sky-Frame Fly makes it possible to enjoy summer weather without being plagued by insects. When not in use, the pleated screen fully retracts out of sight into the frame.

**For technical details, see page 26.**

### Sky-Frame Drive

The electric drive facilitates straightforward and virtually noiseless operation of the sliding panels at the press of a button.

**For technical details, see page 28.**

### Sky-Frame Pocket

When Sky-Frame Pocket is opened, the window panels slide into the wall, allowing the living spaces to be completely open.

**For technical details, see page 30.**

### Sky-Frame Inline

Sky-Frame Inline's elegant posts, with a width of just 1 ¾", fit flush with the frameless glass panels, resulting in a seamless and fluid glass membrane.

**For technical details, see page 32.**

### Sky-Frame Guard

The Sky-Frame sliding door system is burglar-resistant and can, where required, be fitted with laminated safety glass and additional security hardware concealed in the frame. Alarm sensors can also be integrated to monitor the doors.

**For technical details, see page 34.**

### Sky-Frame Gun

Security means quality of life, which is why Sky-Frame Gun features insulated security glass, reinforced frames, and vertical profiles to protect against gunfire.

**For technical details, see page 36.**

### Sky-Frame Hurricane

Sky-Frame's hurricane-tested, frameless sliding windows are some of the largest on the international market.

They comply with the criteria for the authoritative standard of the industry – High Velocity Hurricane Zone (HVHZ) according to the Florida Building Code.

**For technical details, see page 38.**

### Sky-Frame Color

Sky-Frame offers the window profiles with colourless anodisation. Alternatively, an individual colour from the RAL, IGP or DB colour systems can be defined for the powder coating or one of six anodized colours can be selected.

**For technical details, see page 44.**

## ENVIRONMENTAL ISSUES

### NFRC

All insulated glass units and technologies are NFRC certified (SKY-M-1) and meet the requirements of the NFRC regulations.

### NAMI

Sky-Frame's factory production monitoring is periodically inspected by the accredited third party NAMI.



# SKY-FRAME CLASSIC



PRODUCT VIDEO 



The name “Classic” evokes the timeless appeal of the rectilinear window system while highlighting its historical significance as the first-ever Sky-Frame system. The sliding doors comprise glass units with aluminum or glass-fiber-reinforced plastic (GRP) perimeter sections. Mounted in streamlined aluminum frames fitted flush with floor and ceiling, each unit rolls fluidly when operated. The system drainage for the flush assembly either runs via a recessed channel or is installed below a raised outdoor floor covering.

#### Vertical floor section, Sky-Frame 2

Floor connection (scale 1:4)

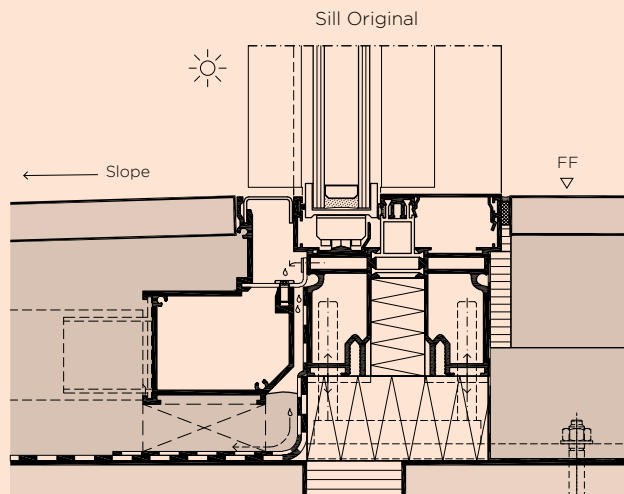
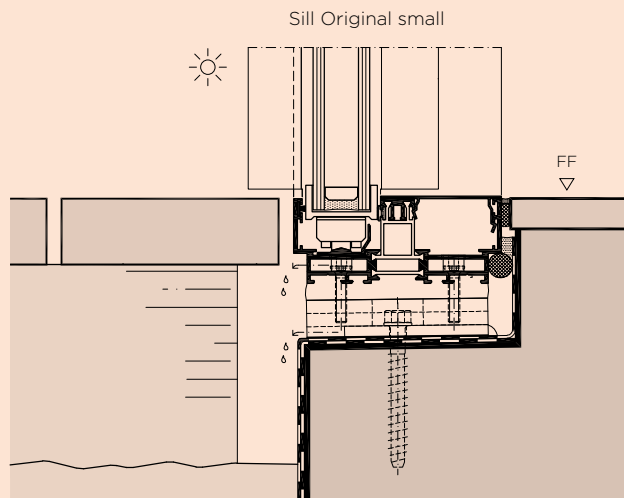

Original small sill is available for countries where a low floor structure is common and compliant.

# SKY-FRAME ARC



Sky-Frame Arc offers sliding glass panels to create curved fronts that lend organic, smooth contours to a residential space. The rounded glass units offer smooth running performance and can be equipped with an automatic drive. Meeting all Sky-Frame standards, the streamlined Arc system is an architectural feature that inspires endless additional design options.

**Opening options**

Straight edge (Classic) and curve (Arc) combination  
Curve combination (Arc)

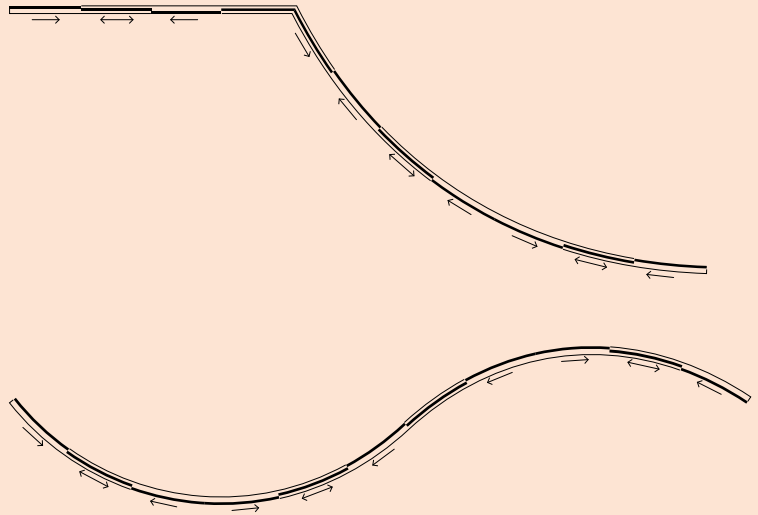
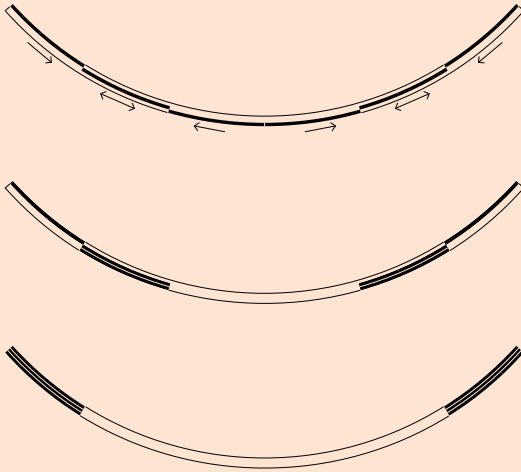

**Feasibility**

The following radii and sizes can easily be fabricated:  
(other radii and wider elements upon request)

Sky-Frame 2 + 3	Sliding elements	Fixed elements
2-tracks	R = 11' 5 13/16" - 32' 9 11/16"	R = 8' 2 7/16" - 32' 9 11/16"
3-tracks	R = 16' 4 7/8" - 32' 9 11/16"	R = 16' 4 7/8" - 32' 9 11/16"

**Sky-Frame 3; possible with electric drive, if:**

2-tracks	R = 12' 5 5/8" - 32' 9 11/16"
3-tracks	R = 16' 4 7/8" - 32' 9 11/16"

Sliding elements:	width x height = max. 6' 6 3/4" x 10' 2 1/16"
Fixed elements:	width x height = max. 7' 10 1/2" x 10' 2 1/16"

# SKY-FRAME SLOPE



Sky-Frame Slope sliding doors can either extend into the room or project outwards from the facade at an angle of up to 20°. The system creates a distinctive spatial geometry while meeting all Sky-Frame standards. The bearing assembly accommodates all vertical and horizontal forces, thereby achieving superior running performance. Regardless of the direction of the door, the drainage system meets all requirements for driving rain resistance.

Doors can tilt either inwards or outwards

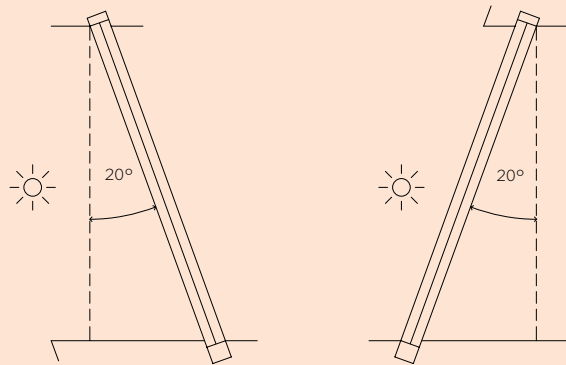

Vertical section, Sky-Frame 2  
Ceiling and floor (scale 1:5)

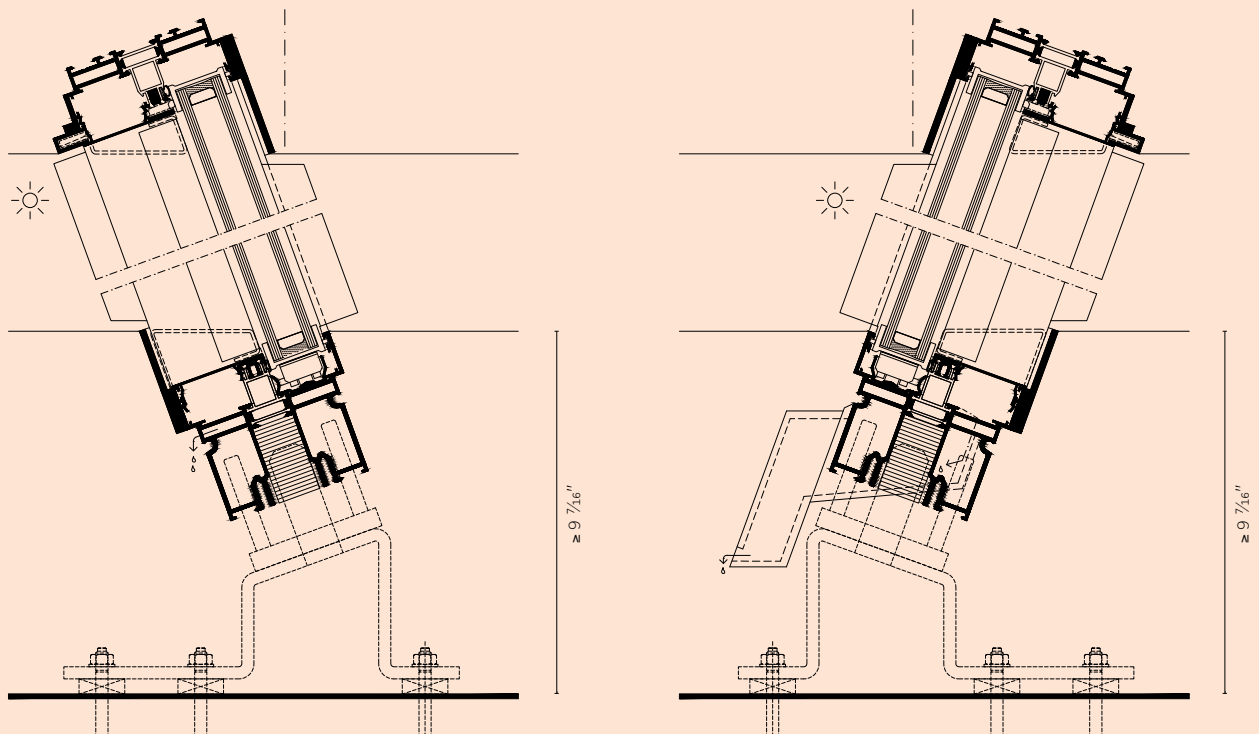

# SKY-FRAME PIVOT



PRODUCT VIDEO 

The Pivot system turns the simple act of opening a door into a creative experience: with a gentle push on the comfortable handle, the doors swing around the asymmetrically located axis, resulting in a temporary spatial structure. This could be the reason why Le Corbusier preferred this style of door. The multipoint locking system guarantees safety and security, while the optional electromechanical locking system ensures additional ease of use.

#### Opening options

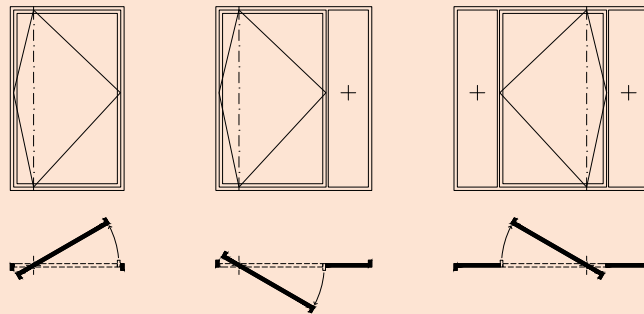

#### Vertical section, Sky-Frame 2

Ceiling and floor connection (scale 1:5)

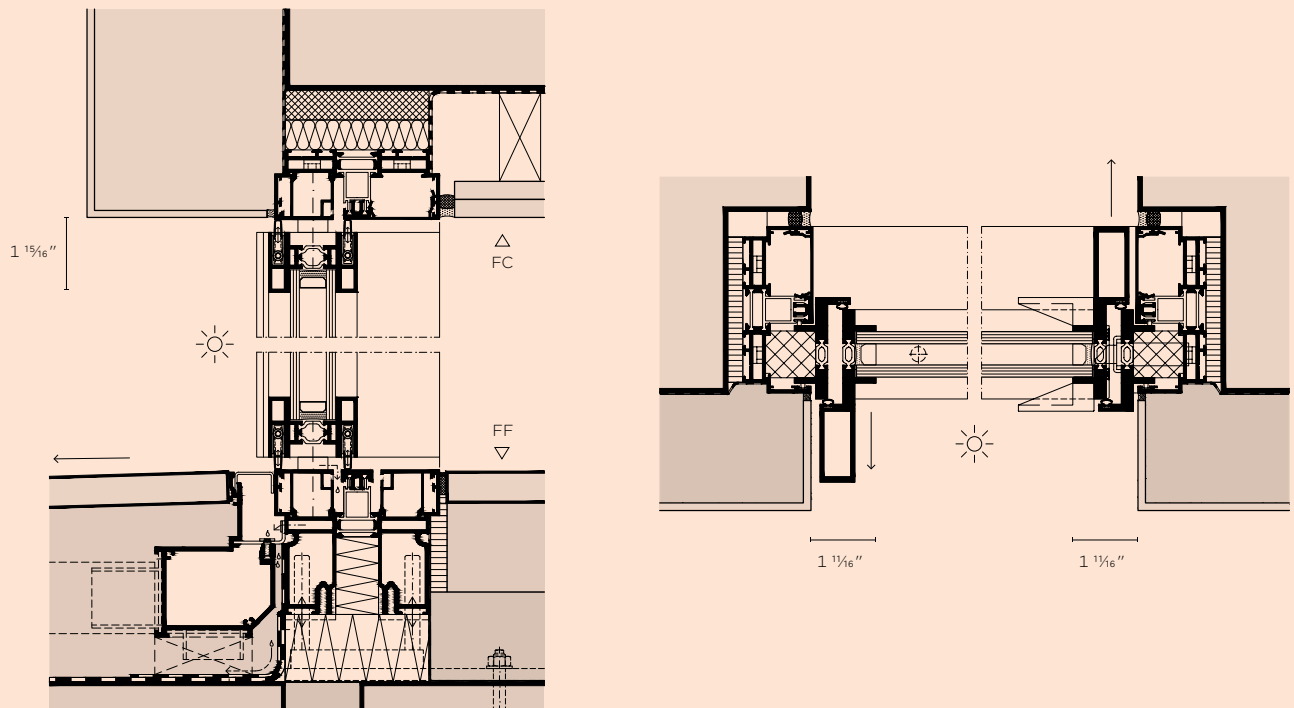

Feasibility	Technology	width × height	weight
Pivot	Sky-Frame 2 + 3	max. 8' 2 7/16" × 14' 9 3/16"	max. 450 kg (992 lb)

# SKY-FRAME ORIGINAL



PRODUCT VIDEO 



A feeling of vast, wide-open space, even when the doors are shut: the seamless transition between indoors and outdoors makes Sky-Frame Original a pioneer of modern design. The frameless doors are fully transparent thanks to a track system that is concealed in the floor – the result of 20 years of development. Compatible with all Sky-Frame products, Sky-Frame Original ensures that the temperature inside remains optimal while the heat and cold remain outside.

### Vertical section, Sky-Frame 2

Ceiling and floor connection (scale 1:5)

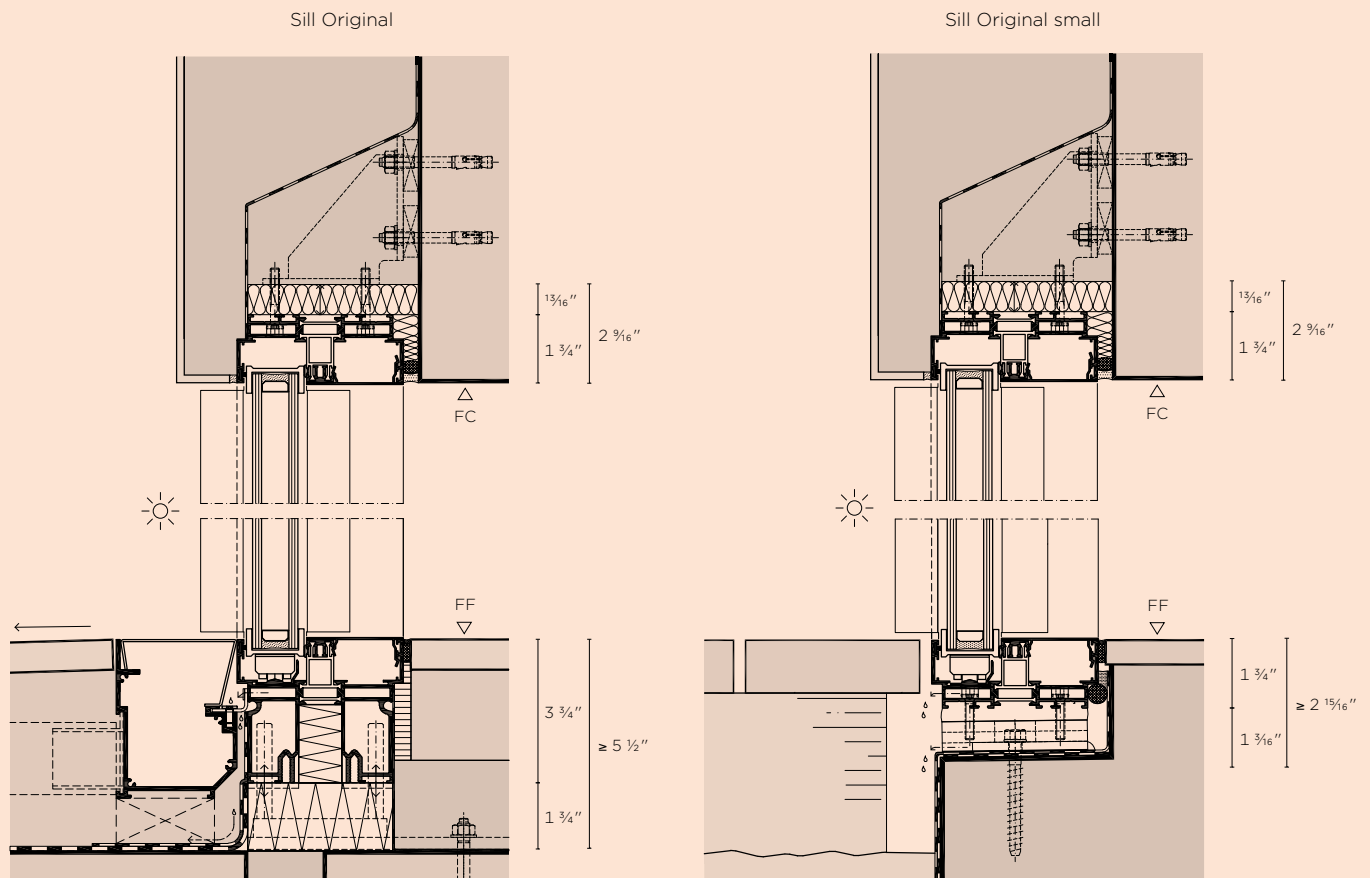

Original small sill is available for countries where a low floor structure is common and compliant.

# SKY-FRAME PLAIN



PRODUCT VIDEO



What sets Sky-Frame Plain apart is the hidden transition between the inside and the outside that is flush-fitted with the floor. The sliding window glides along a narrow gap in the floor. The space between these tracks is covered by the same flooring as the interior of the room, which reinforces the feeling of a free-flowing transition between indoors and outdoors. As soon as the windows are open, this seamless transition becomes a pleasing experience. With its triple-glazed elements, Sky-Frame 3 with Option Plain is insulated to an optimum standard and can therefore also be installed in cold regions. Its innovative system layout makes maintenance and cleaning effortless, even in installed condition.

**Vertical section, Sky-Frame 2 with Option Plain**  
Ceiling and floor connection (scale 1:5)

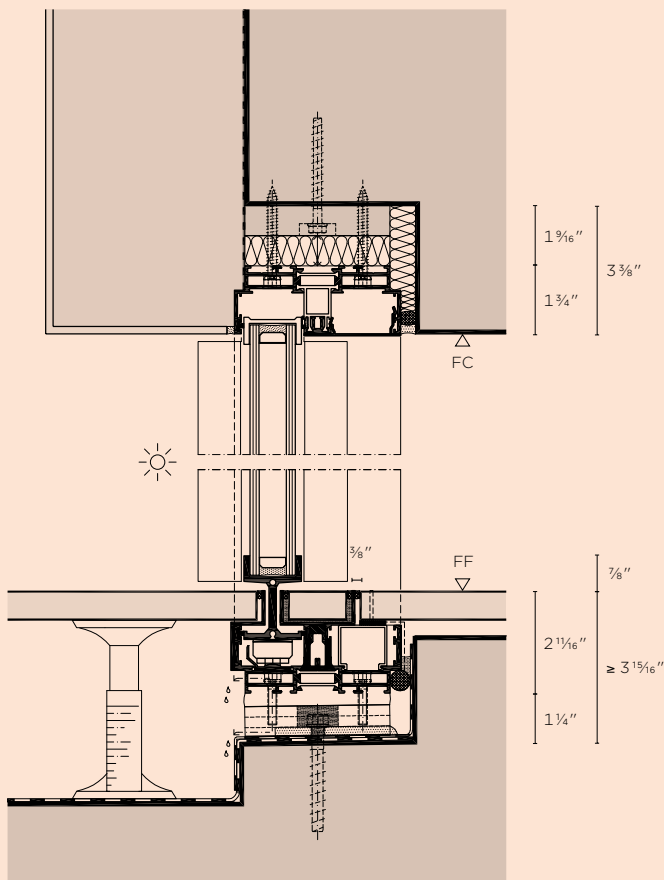

**Vertical section, Sky-Frame 3 with Option Plain**  
Ceiling and floor connection (scale 1:5)

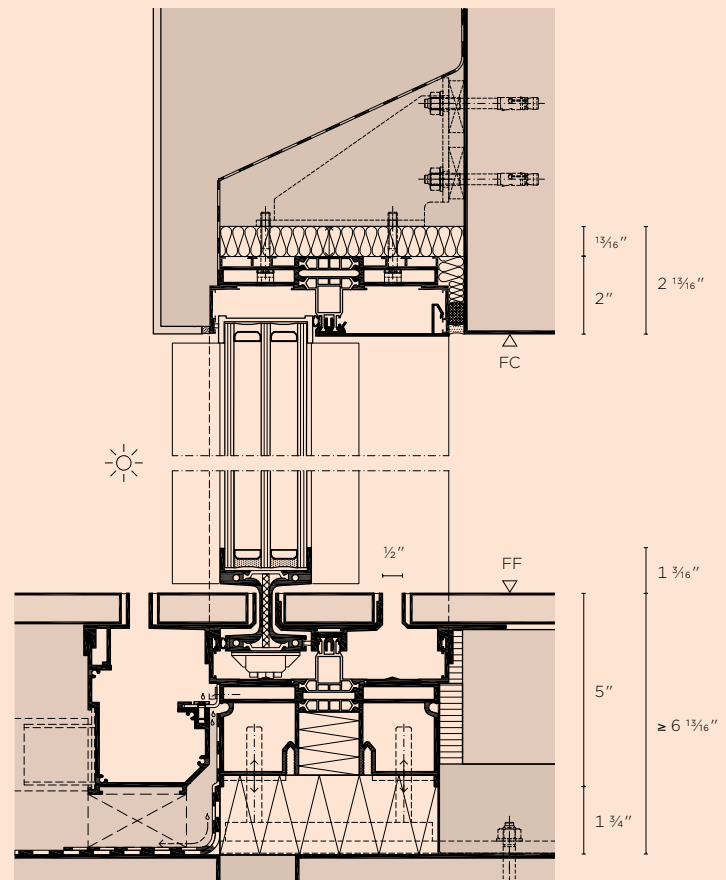

# SKY-FRAME 1-3



The requirements for the thermal insulation, sound protection and wind-load stability vary depending on the situation and whether single glazing will suffice or multiple glazing is required. No matter the requirements, Sky-Frame 1-3 provides the right solution.

**Comparison** (scale 1:2)

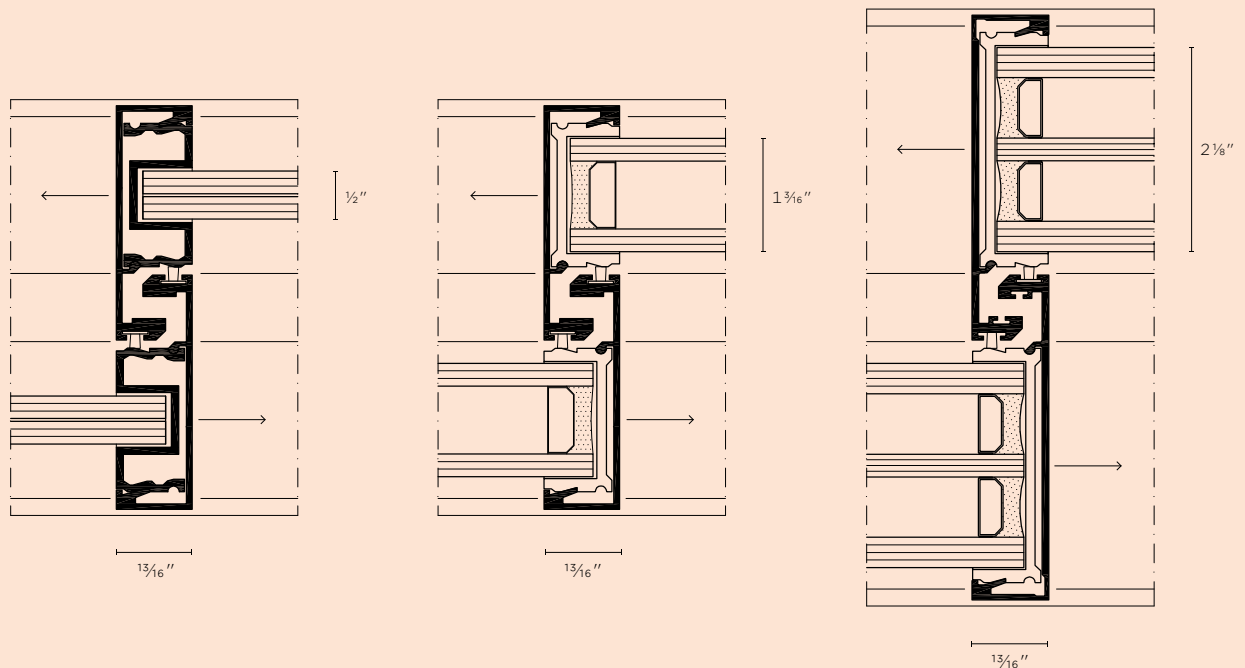

**Sky-Frame 1**  
(glass 1/2")

**Sky-Frame 2**  
(glass 1 3/16")

**Sky-Frame 3**  
(glass 2 1/8")

# SKY-FRAME 1

The single-glazed Sky-Frame 1 units are suitable for applications without thermal insulation requirements.

Characteristics	Sky-Frame 1	Features
Panel sizes	10' 6" × 13' (larger on request)	Sky-Frame Fly (insect screen)
Single glazing	½"	Sky-Frame Drive: single, telescopic (3+3 panels)
Daylight/glass ratio	98%	Connection to alarm system: - Position monitoring - Deadbolt monitoring
Watertightness to driving rain*	15 psf, with heavy rain device (GDE)	
Air permeability*	≥0.06 cfm/ft <sup>2</sup>	
Resistance to wind load*	tested up to 50 psf	
Product ratings*	R-PG30, AW-PG50 <small>(AAMA/WDMA/CSA 101/I.S 2/A440-08)</small>	

**Profile options** (All profile details are referenced in our Technical Documentation)

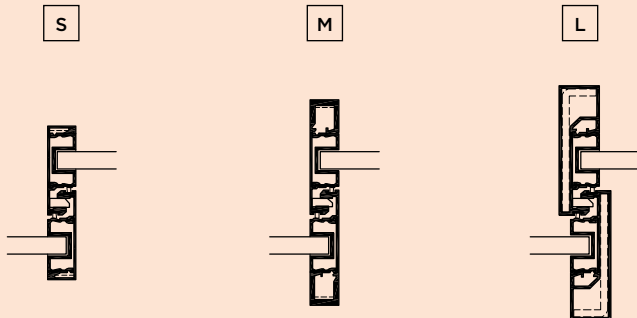

\* Performances based on Sky-Frame 2

**Horizontal section**

Side wall junctions (scale 1:5)

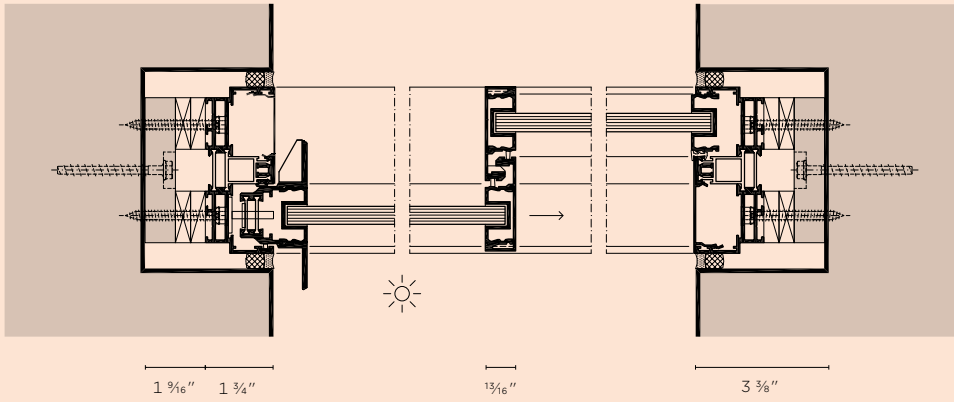

**Vertical section**

Floor and ceiling junctions (scale 1:5)

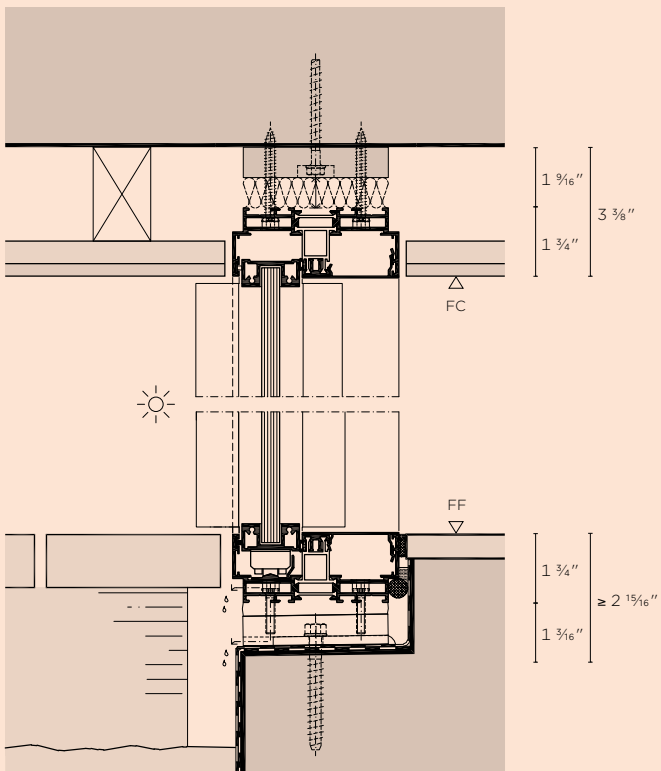

# SKY-FRAME 2

The excellent sound and thermal control standards met by Sky-Frame 2 have made it the most popular Sky-Frame solution. The slim (only 1  $\frac{3}{16}$  inches) double-glazed insulating glass assembly has proven to be an outstanding performer in a wide range of climate zones.

Characteristics	Sky-Frame 2	Features
U-value	0.3 - 0.35	Sky-Frame Fly (insect screen)
Panel sizes	7' 6" × 13' (larger on request)	Sky-Frame Drive: single, telescopic (3+3 panels)
Insulating glass (double glazing)	1 $\frac{3}{16}$ "	Sky-Frame Guard: - RC 2 (EN 1628, 1629, 1630/EN 1627*)
Daylight/glass ratio	98%	Connection to alarm system: - Position monitoring - Deadbolt monitoring - Glass breakage sensor
Watertightness to driving rain up to	15 psf, with heavy rain device (GDE)	
Air permeability	≥0.06 cfm/ft <sup>2</sup>	
Resistance to wind load	tested up to 50 psf	
Sound insulation up to	R <sub>w,P</sub> 37 dB (EN ISO 717-1/EN ISO 10140)	
NFRC	certified (SKY-M-1)	
NAMI	certified	
Product ratings	R-PG30, AW-PG50 (AAMA/WDMA/CSA 101/1S.2/ A440-08)	
EPD	certified (EPD-SF-27.0)	

Values apply to Sky-Frame 2 with the Original option

**Profile options** (All profile details are referenced in our Technical Documentation)

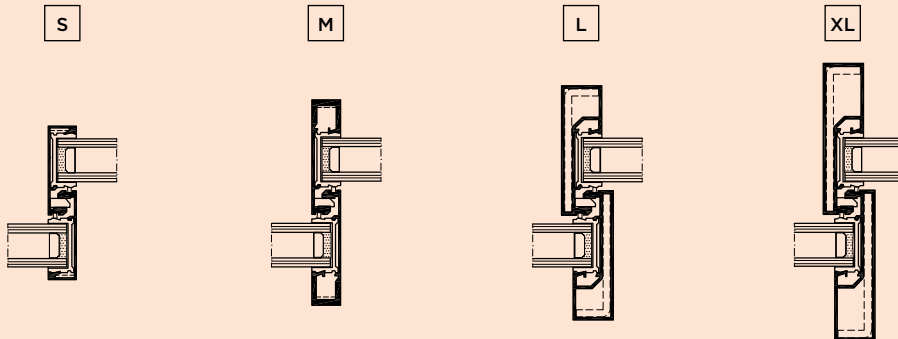

Classification standard / test standard



**Horizontal section**

Side wall junctions (scale 1:5)  
and temperature profile

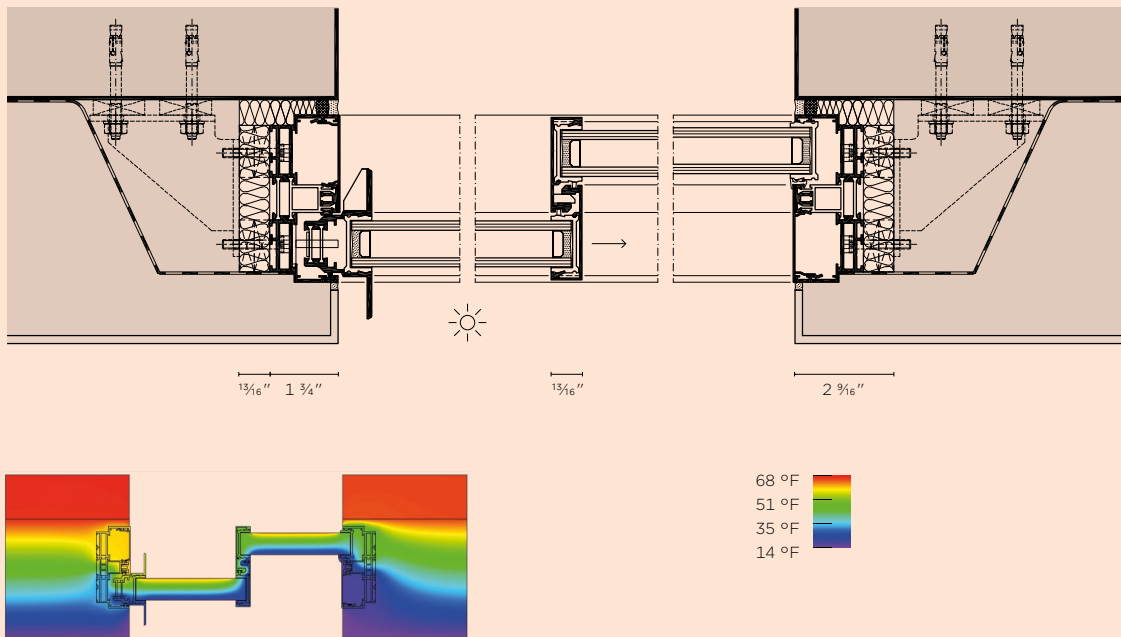

**Vertical section**

Floor and ceiling junctions (scale 1:5)  
and temperature profile

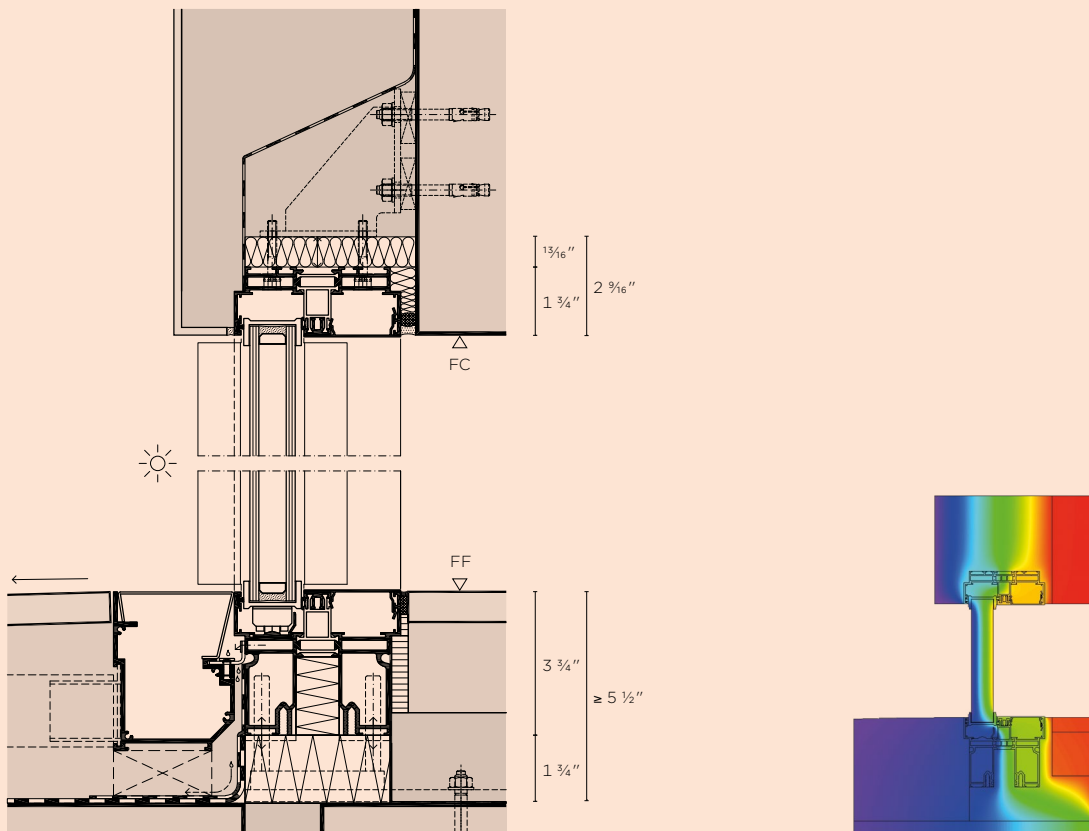

# SKY-FRAME 3

The Sky-Frame 3 technology, with its 2 1/8-inches thick insulating glass units, meets the highest standards. The triple-glazed insulating panels offer extra stability and even greater resistance to wind. The choice between several insulation levels will insure the highest requirements in terms of thermal insulation.

Characteristics	Sky-Frame 3	Features
U-value	0.22 - 0.23	Sky-Frame Fly (insect screen)
Panel sizes	7' 6" × 13' (larger on request)	Sky-Frame Drive: single, telescopic (2+2 panels)
Insulating glass (triple glazing)	2 1/8"	Sky-Frame Guard: - RC 2 (EN 1628, 1629, 1630/EN 1627*)
Daylight/glass ratio	98%	Connection to alarm system: - Position monitoring - Deadbolt monitoring - Glass breakage sensor
Watertightness to driving rain up to*	15 psf, with heavy rain device (GDE)	
Air permeability*	≥0.06 cfm/ft <sup>2</sup>	
Resistance to wind load*	tested up to 50 psf	
Sound insulation up to	R <sub>w,P</sub> 44 dB (EN ISO 717-1/EN ISO 10140) OITC 42 dB (ASTM E1332)	
NFRC	certified (SKY-M-1)	
NAMI	certified	
Product ratings*	R-PG30, AW-PG50 (AAMA/WDMA/CSA 101/I.S.2/A440-08)	
EPD	certified (EPD-SF-27, 0)	

Values apply to Sky-Frame 3 with the Original option

## Profile options (All profile details are referenced in our Technical Documentation)

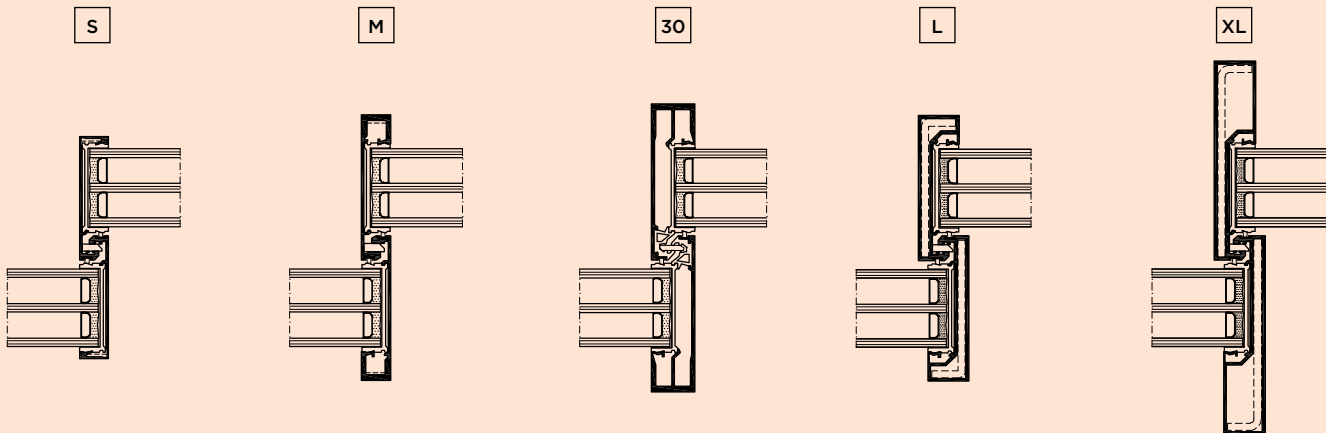

\* Performances based on Sky-Frame 2

Classification standard / test standard

**Horizontal section**

Side wall junctions (scale 1:5)  
and temperature profile

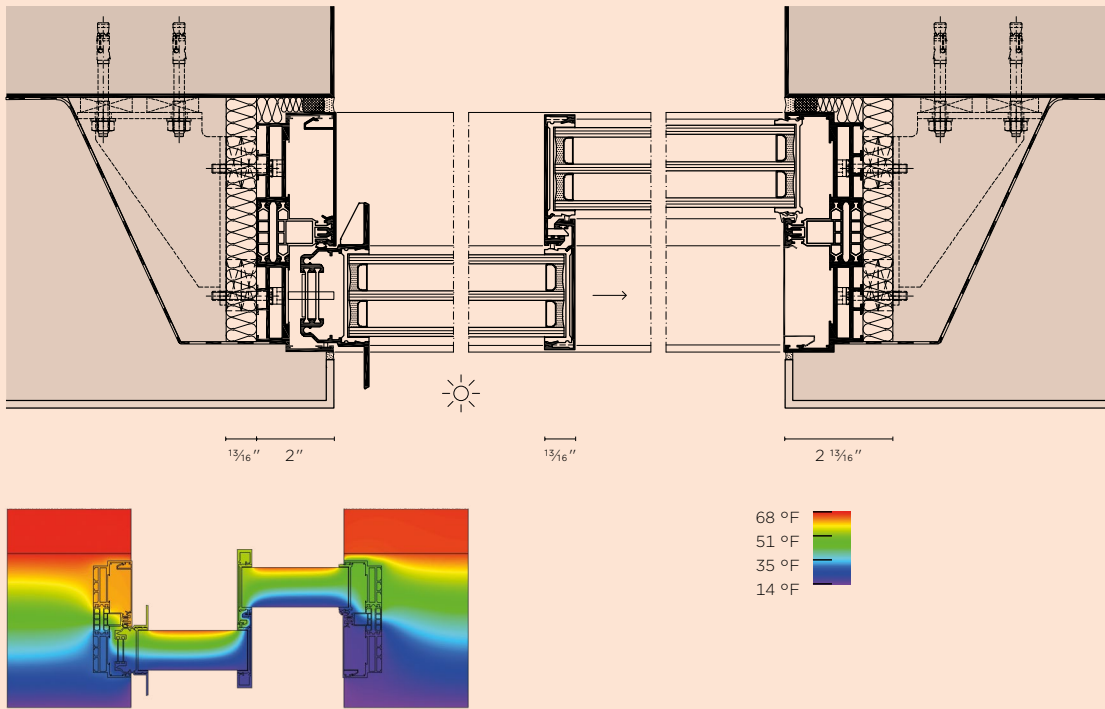

**Vertical section**

Floor and ceiling junctions (scale 1:5)  
and temperature profile

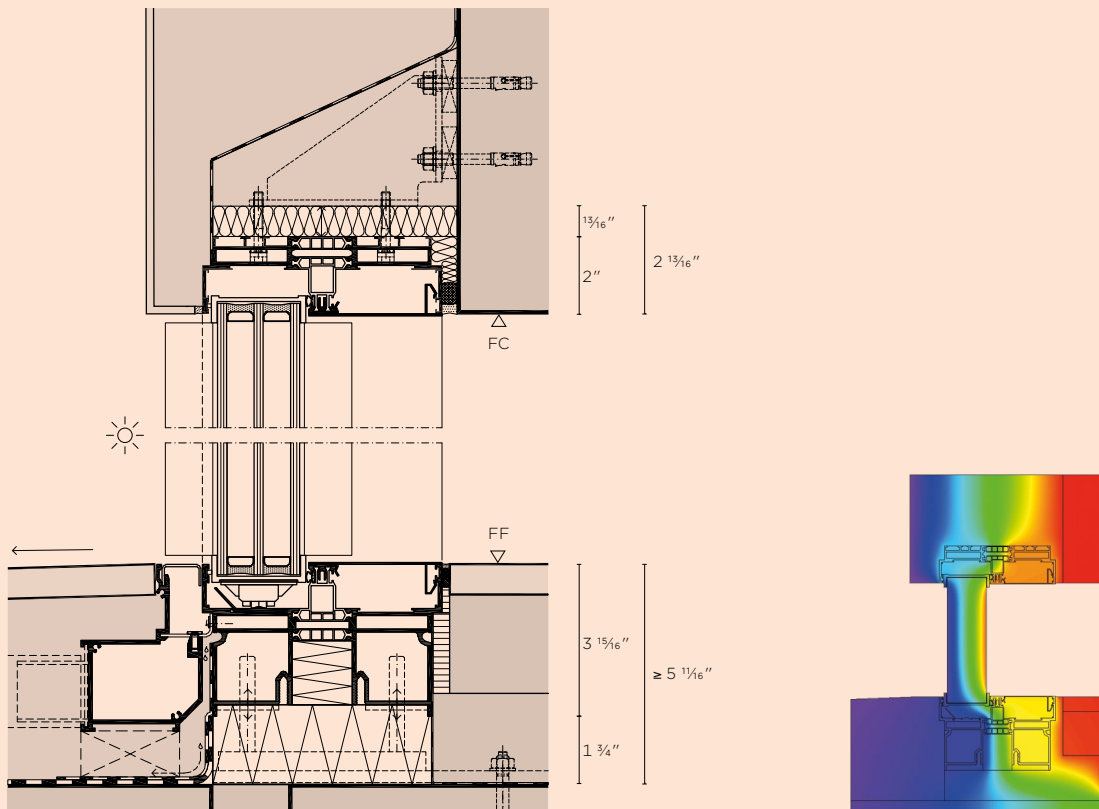

# SKY-FRAME FLY



PRODUCT VIDEO 

The Sky-Frame Fly insect screen is a minimalistic way to keep insects at bay. The frameless, pleated screen fully retracts into the frame when not in use. The combination of tear-resistant Vectran fiber tension cords and an integral system section guarantee maximum stability and weather resistance. Fly extends up to 40".

**Horizontal section (scale 1:5)**

Insect screen in closed position (top drawing)

Insect screen in open position (bottom drawing)

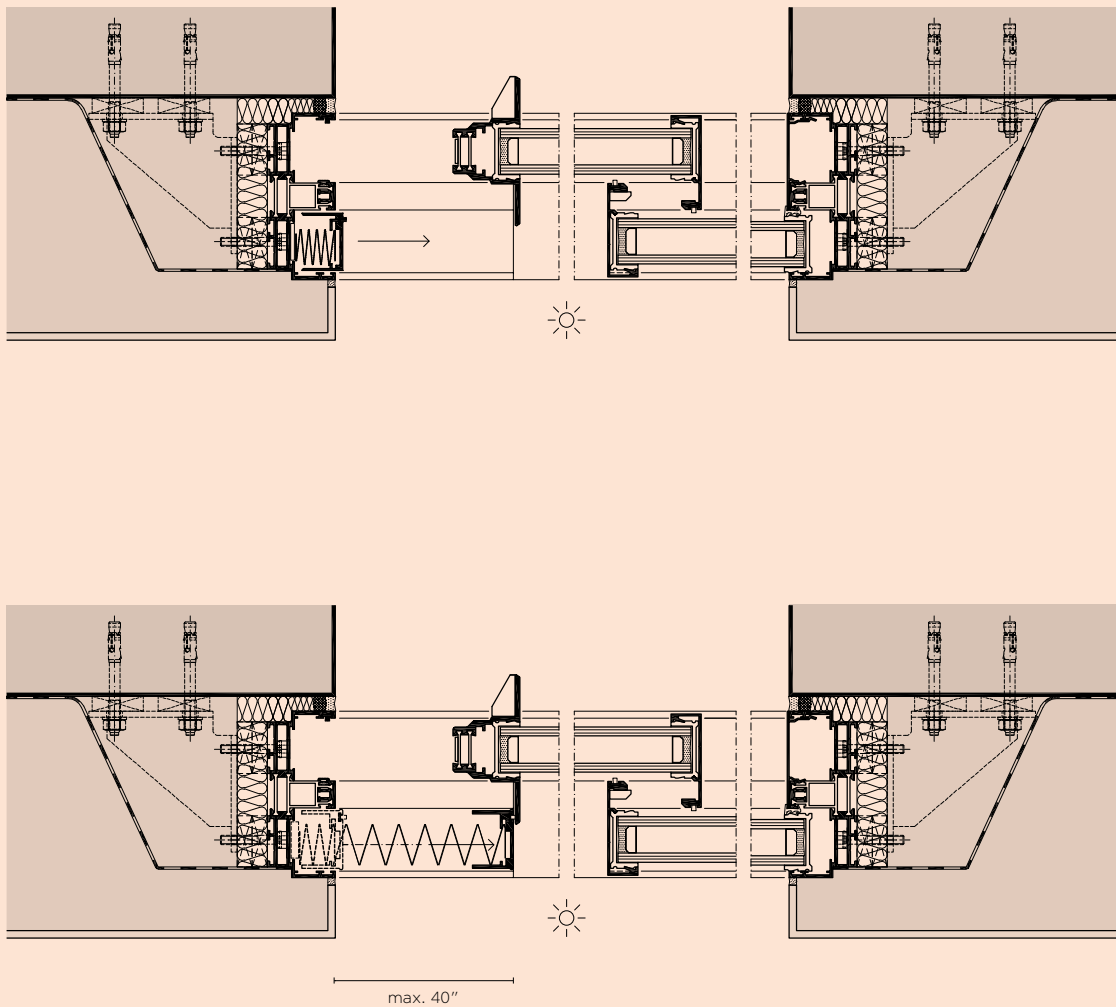

# SKY-FRAME DRIVE



TOUCH 

DRIVE 

Sky-Frame Drive's electric drive facilitates simple and virtually noiseless operation of up to 6 (3+3) sliding panels at the press of a button. The drive is concealed in the ceiling section and allows the window panels to move automatically. The new Sky-Frame Touch control button is a convenient way to open and close sliding windows using the electric drive. Entire systems can be elegantly opened, closed or stopped at any point right at the window by applying gentle pressure on the rocker switch, which is unobtrusively integrated into the locking handle.

#### Side view

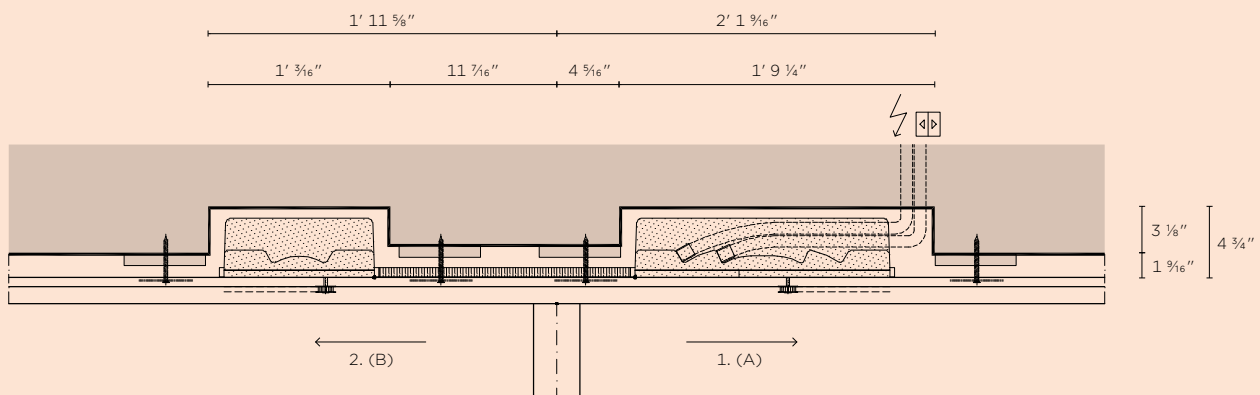

#### Opening options

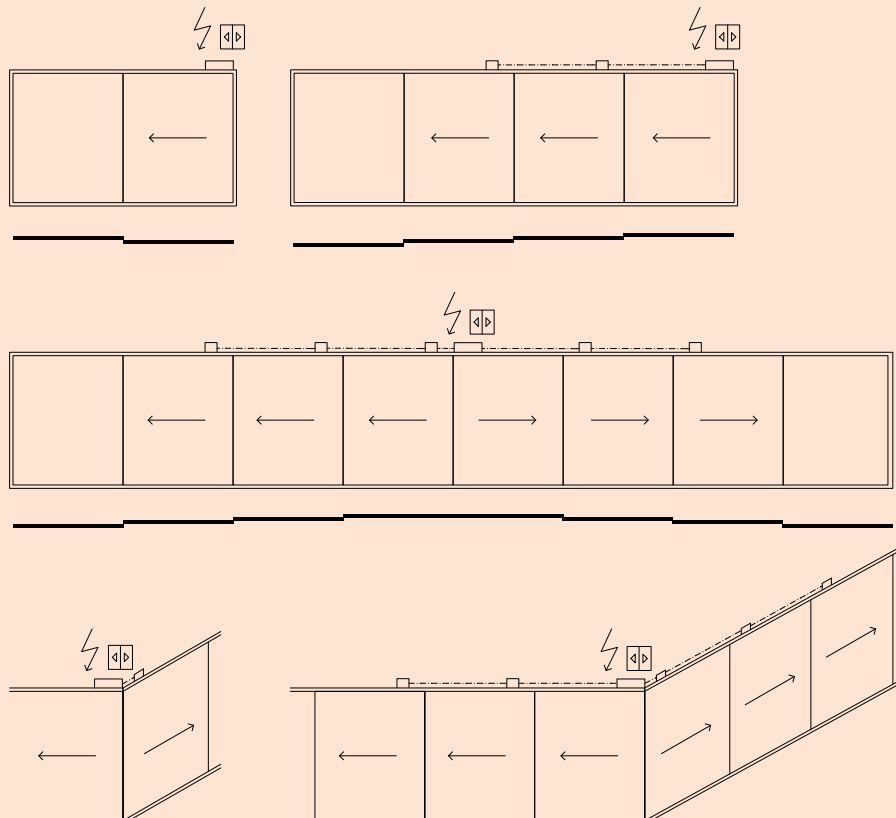

# SKY-FRAME POCKET



PRODUCT VIDEO 



With the Sky-Frame Pocket solution, rooms can be completely opened without any visible glass leaves. The sliding panels are recessed and hidden away from sight. Additional features, such as Sky-Frame Drive (electrically driven opening and closing), are also available.

### Horizontal section, Sky-Frame 3

Side wall junction (scale 1:5)

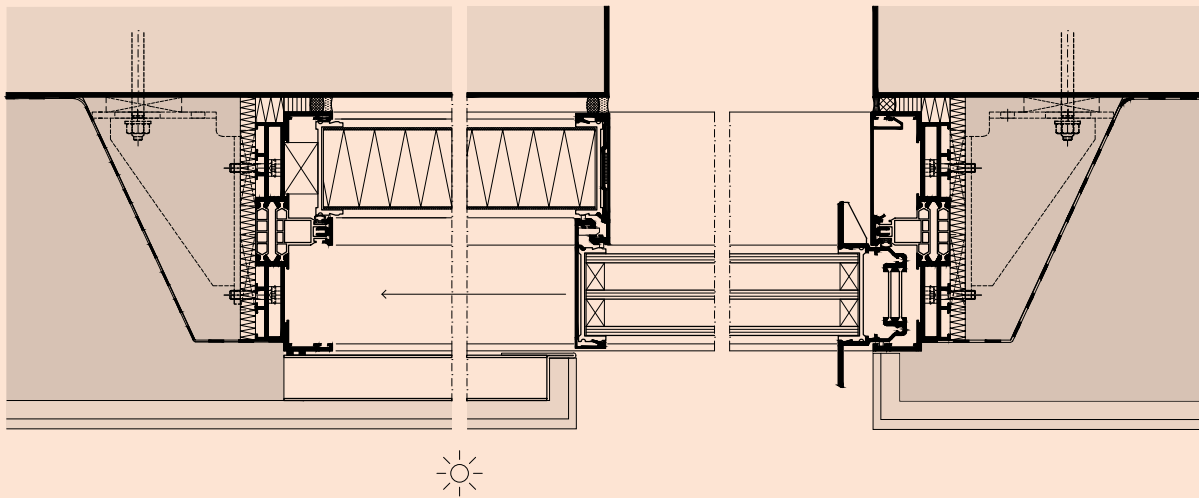

### Opening options

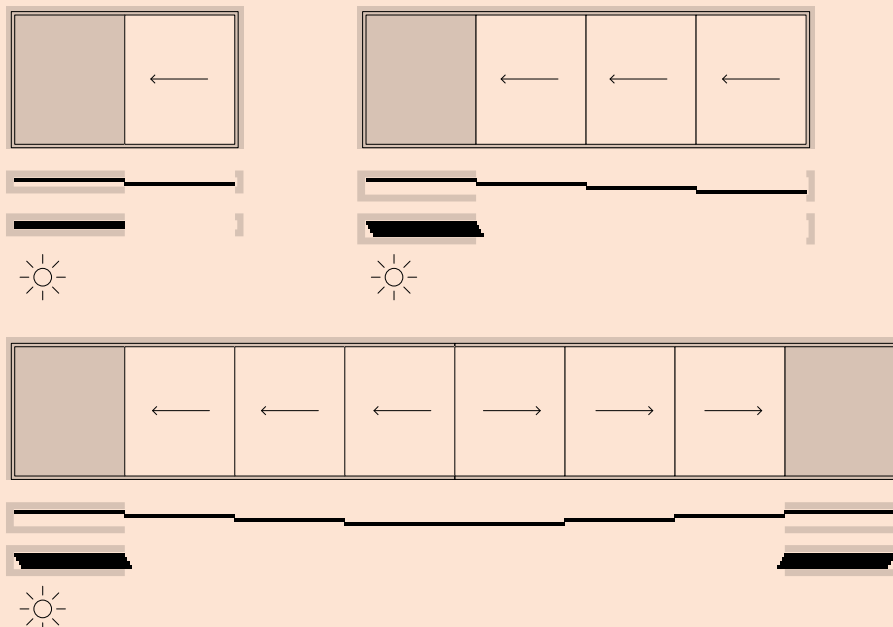

# SKY-FRAME INLINE



The Sky-Frame system is supplemented by elegant filigree posts, which have a minimal width of just  $1\frac{3}{16}$ ". It is available in three installation depths ( $2\frac{5}{8}$ ",  $3\frac{9}{16}$ ",  $4\frac{5}{16}$ ") and can be reinforced with up to four steel profile inserts for higher static specifications. Frameless fixed glass panels can be combined with sliding doors, resulting in a seamless and fluid glass membrane.

**Sky-Frame 2**

Double glazing (scale 1:5)

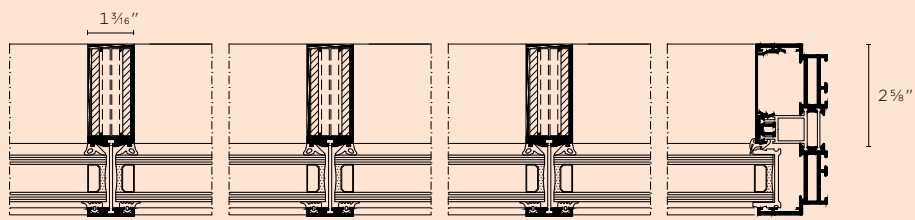
**Sky-Frame 3**

Filigree post combined with sliding element (scale 1:5)

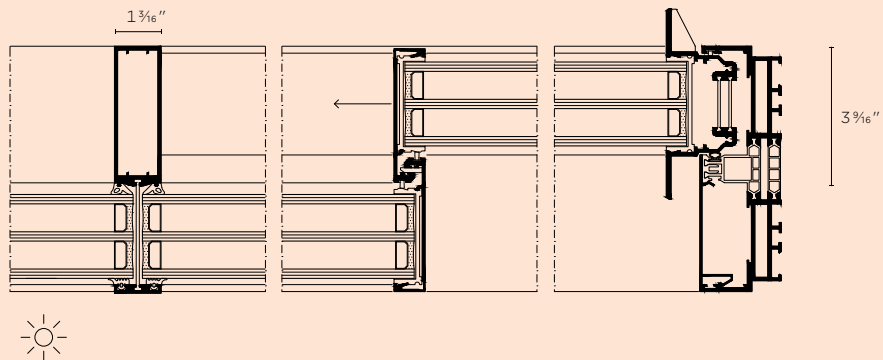

# SKY-FRAME GUARD



Sky-Frame Guard offers outstanding burglar resistance thanks to an adhesive bond between the insulating glass assembly and the GRP sections, as well as a multi-point locking system. Various additional components are available to meet further security requirements.

#### Electronic components

- P: Position monitoring (leaf)
- R: Deadbolt monitoring (lock)
- G: Glass breakage sensor (alarm loop)

These three security parameters can be electronically monitored by alarm sensors concealed in the unit, and the status information can be transmitted to a burglar alarm system.

#### Mechanical components

The Sky-Frame 2 and Sky-Frame 3 technologies have been inspected by ift Rosenheim and comply with the following anti-burglary protection class:  
RC 2 (EN 1628, 1629, 1630/EN 1627)  
up to RC 4 + PAS24 on request

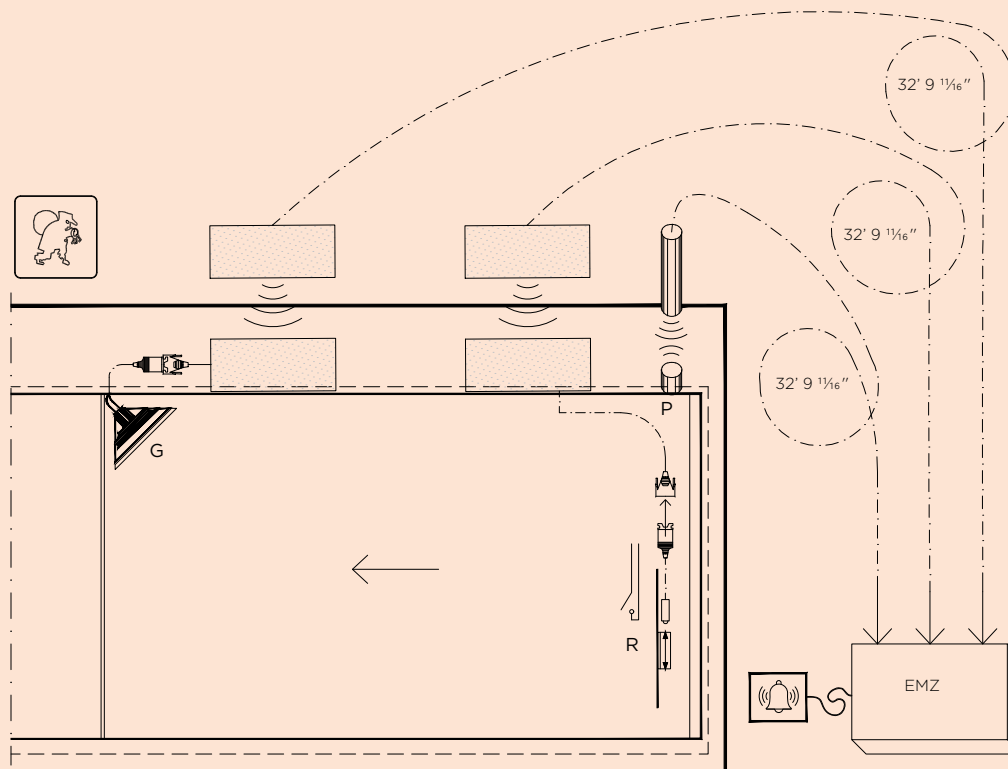

# SKY-FRAME GUN



With special insulated security glass (2-IG bullet resistant glass), reinforced frames, vertical profiles and defined building joints, Sky-Frame 3 Gun ensures optimal protection from gunfire.

The Swiss Federal Office for Defence Procurement (armasuisse) has rated Sky-Frame 3 Gun as FB4, NS (.44 Magnum, no splinters).

### Bullet resistance

Reinforced profiles with bulletproof glass (scale 1:5)

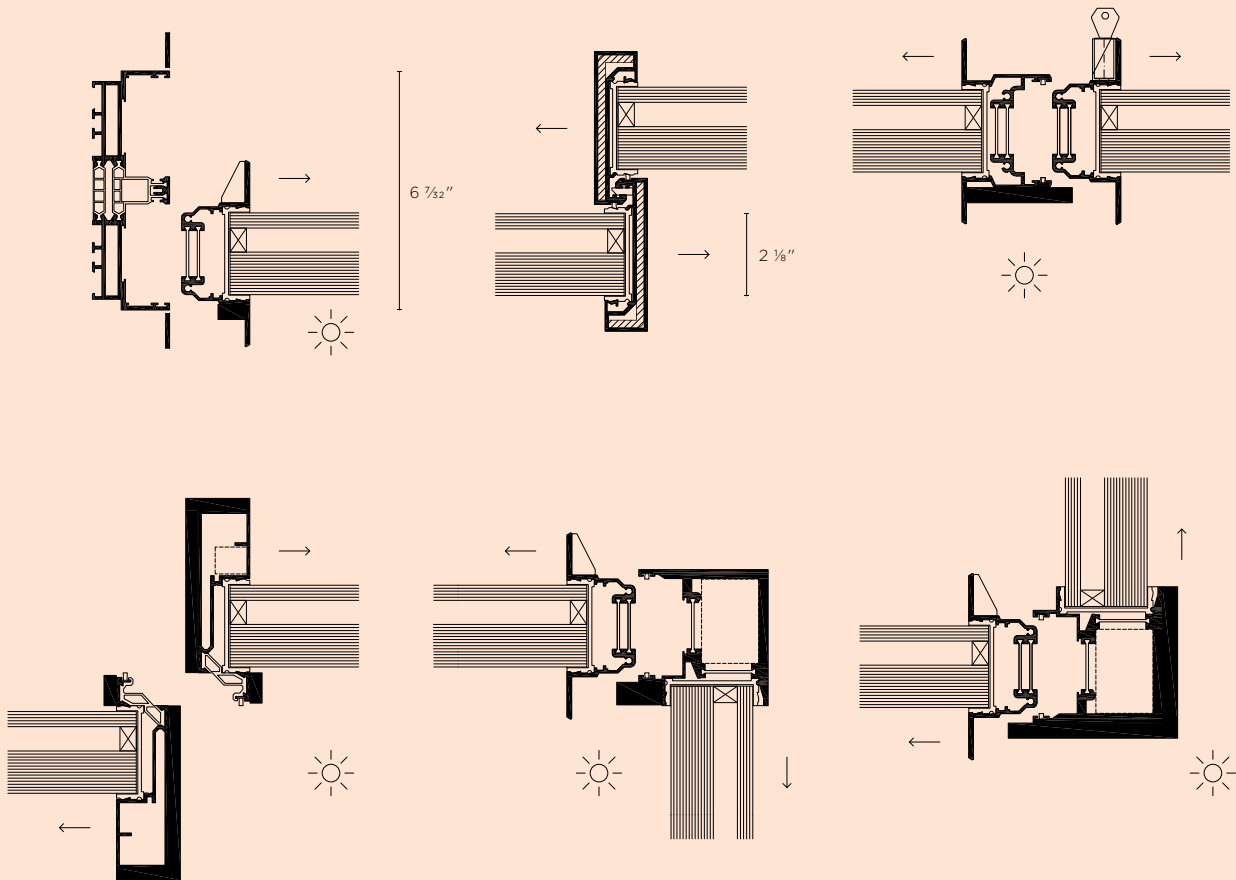

# SKY-FRAME HURRICANE





---

Sky-Frame Hurricane sliding doors have exceeded the most stringent hurricane impact tests, and are compliant with the High Velocity Hurricane Zone (HVHZ) criteria as defined by the Florida Building Code - considered to be the gold standard in the industry. Fulfilling the requirements of Miami-Dade County, Sky-Frame's 91-inch × 138-inch panels are one of the largest hurricane-rated frameless sliding doors on the world market. The values of 1200 Pa (25 psf) reached during the driving-rain tests are the one of the world's highest, and greatly contribute to the water-resistance of the windows. The sliding doors can be motorized or manually operated with a wide range of opening options and a slim 1 ⅛" sight line offers an unbounded spatial experience for exceptional architecture. Multi-tracks allow an unlimited number of sliding doors to be installed next to each other.

---

# SKY-FRAME HURRICANE

Characteristics	Sky-Frame 3 Hurricane	Sky-Frame 3 Hurricane	Features
Design pressure	65 psf 3.1 kN/m <sup>2</sup>	75 psf 3.6 kN/m <sup>2</sup>	Sky-Frame Pocket
Sliding or fixed panel <small>(max. width × height)</small>	*7'7" × 11'6" 2311 mm × 3505 mm	*5' × 11'6" 1524 mm × 3505 mm	Sky-Frame Fly
Max. panel area <small>*all possible dimensions on request</small>	87 ft <sup>2</sup> 8.1 m <sup>2</sup>	75 ft <sup>2</sup> 6.9 m <sup>2</sup>	Sky-Frame Drive
Insulating glass (double glazing)	1 5/8" (2-IG) 40.5 mm LSG-TSG 6/6.6 SGP / 12 / LSG-TSG 6/6.6 SGP		Sky-Frame Guard: Connection to alarm system: - Deadbolt monitoring - Position monitoring
Watertightness to driving rain	25 psf		
Rating <small>(Tas 201/202/203)</small>	HVHZ, wind zone 4, large and small missile impact		
NFRC	available		

## Configuration

Number of tracks	2-4
Number of panels	no limit
Configuration restrictions	no slider on the inner track
Steel-reinforced labyrinth	available
Centre opening offset	available
Centre opening on same level	available
Edge opening	available
Corner opening	not available
Fixed corner glazing	not available
Inline	not available

Institute / Authority



**Vertical section 2 track**  
(M 1:5)

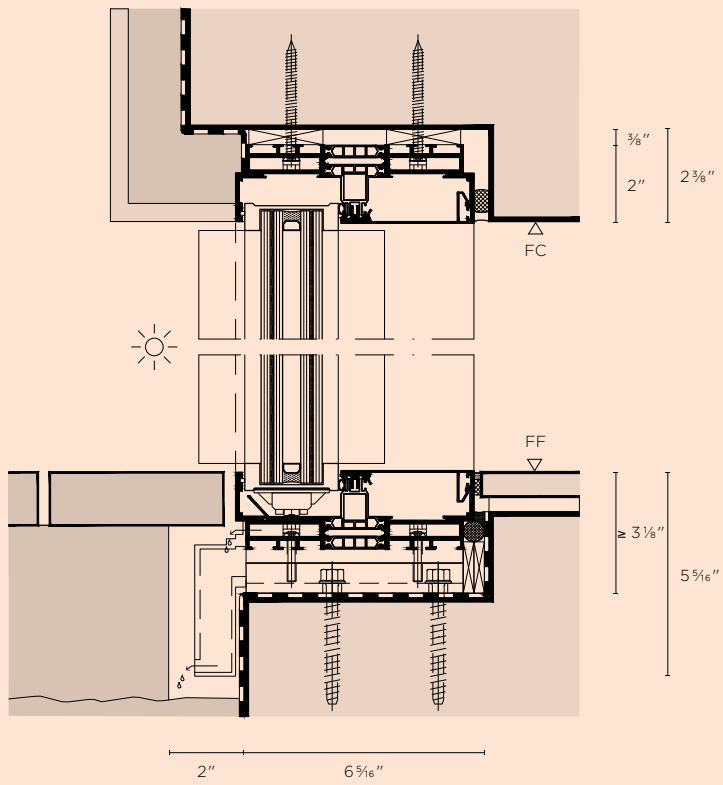

**Horizontal section**  
(M 1:5)

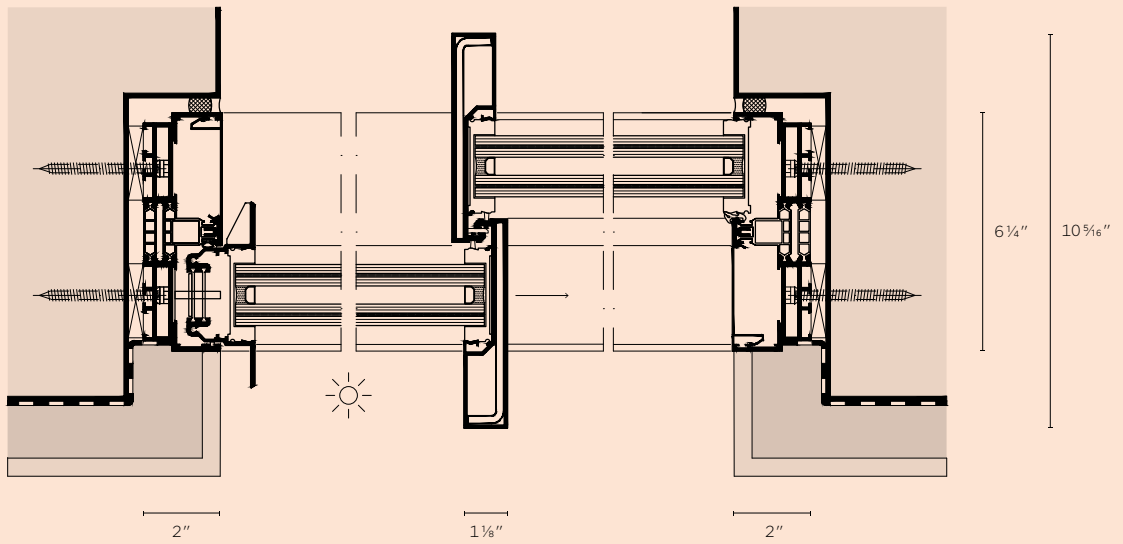





# SKY-FRAME COLOR



Customize your own Sky-Frame sliding doors: choose your profile color and our experienced glaziers, metalworkers and coating specialists, all of whom are truly passionate about what they do, will create the ultimate system tailored to your specifics, resulting in a compelling, seamless architectural element.

### Unique colors

In addition to the anodized colors shown below, you can choose any color from a range of palettes (RAL, IGP, DB) for the powder coating.



### Anodized colors



#### E6 EV1

colorless anodized  
standard



#### Colinal 3115

chemically matted  
surcharge

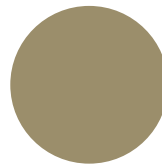

#### Colinal 3145

chemically matted  
surcharge

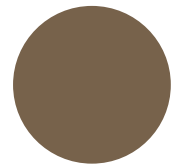

#### Colinal 3165

chemically matted  
surcharge

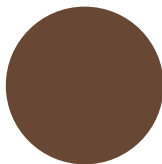

#### Colinal 3175

chemically matted  
surcharge

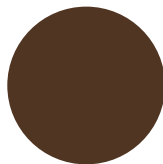

#### Colinal 3178

chemically matted  
surcharge

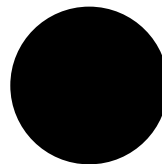

#### Colinal 3180

chemically matted  
surcharge

# SWISS MADE.



The spectacular frameless glass panels and flush transitions allow inside and outside to merge seamlessly into one another to form a living space. Ever since the first Sky-Frame window was installed in 2002, the Swiss company has helped to make more than 10 000 individual lifestyle dreams come true and create innovative living spaces around the world.

Sky-Frame develops and manufactures all of its premium products in Switzerland and regularly wins renowned design and business awards. Together with universities and research institutions, Sky-Frame continuously drives forward new solutions for ambitious living concepts.



Sky-Frame's immense passion and in-depth understanding of architecture, spatial design, and technology has made it the leading international supplier of frameless sliding window systems.



# WE LOVE WHAT WE DO. REFERENCES.



1



2



3



4



5



6



7



8

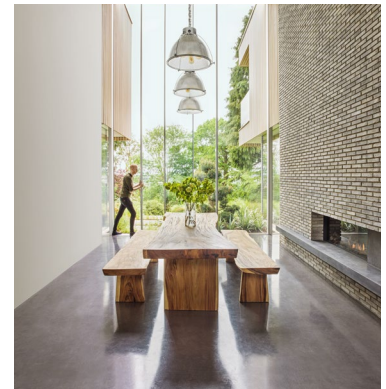

9

1, 2 Wohnhaus Freundorf, Austria. Architecture: Project A01, Austria. 3 Vitrahaus, Germany. Architecture: Herzog & de Meuron, Switzerland.  
4 Villa in Utrecht, Netherlands. Architecture: Zecc Architects BV, Netherlands. 5 Penthouse in New York, USA. Architecture: UNStudio, Netherlands.  
6 Haus G, Germany. Architecture: ATP Sphere, Netherlands. 7 Villa Kavel 01, Netherlands. Architecture: Studioninedots, Netherlands.  
8 Orum, USA. Architecture: SPF:architects, USA. 9 Caversham, United Kingdom. Architecture: Gregory Phillips Architects, United Kingdom.

**Head Office**

Sky-Frame Frauenfeld, Switzerland  
[www.sky-frame.com](http://www.sky-frame.com)

**Sky-Frame Branches**

Austria, Vienna  
 Great Britain, London  
 Italy, Milan  
 Switzerland, Rothrist  
 USA, Los Angeles

**Sky-Frame Partners**

Australia	Mexico
Austria	Monaco
Belgium	Netherlands
Canada	Norway
China	Peru
Czech Republic	Philippines
Denmark	Poland
Estonia	Portugal
France	Russia
French Antilles	Singapore
Germany	Slovakia
Hong Kong	South Korea
Hungary	Spain
Ireland	Sweden
Italy	Switzerland
Japan	Taiwan
Kazakhstan	Ukraine
Latvia	United Arab Emirates
Liechtenstein	United Kingdom
Lithuania	USA

For further details, please visit our website:  
[www.sky-frame.com](http://www.sky-frame.com)

**Architecture**

Will Architektur, Austria (cover page, page 18)  
 Bembé und Dellinger Architekten, Germany (page 6)  
 Lab 32 Architecten, Netherlands (page 8)  
 Oppenheim Architecture, Switzerland (page 12)  
 Sergio Caverio, Switzerland (page 14)  
 Tec Architecture, Switzerland (page 26)  
 Peter Pichler Architecture, Italy (page 28)  
 Biehler Weith Associated, Germany (page 30)  
 Gus Wüstemann, Switzerland and Spain (page 32)  
 Zoran Bodrozić, Austria (page 36)  
 Peter Kunz, Switzerland (page 44, 46)

**Copyright**

© 2025 Sky-Frame

**Concept and Design**

STUDIO NEO, Switzerland

**Text**

Jung von Matt, Switzerland

**Photography**

Paul Ott, Austria (cover page, page 18)  
 Brigida González, Germany (page 6, 14, 30, 48)  
 René de Wit, Netherlands (page 8)  
 Zooey Braun, Germany (page 12)  
 Bruno Helbling, Switzerland (page 26, 32)  
 Oskar da Riz, Italy (page 28)  
 Robert Niederl Photography, Austria (page 36)  
 Claudia Luperto, Switzerland (page 44, 46)  
 Mel Yates, United Kingdom (page 48)  
 Matthew Momberger, USA (page 48)  
 Cornbread Works, Netherlands (page 48)  
 Tom Bisig, Switzerland (page 48)  
 Peter Cuypers, Netherlands (page 48)  
 Iwan Baan, Netherlands (page 48)

**A VIEW,  
NOT A  
WINDOW.**